

NO.	DESCRIPTION	DATE

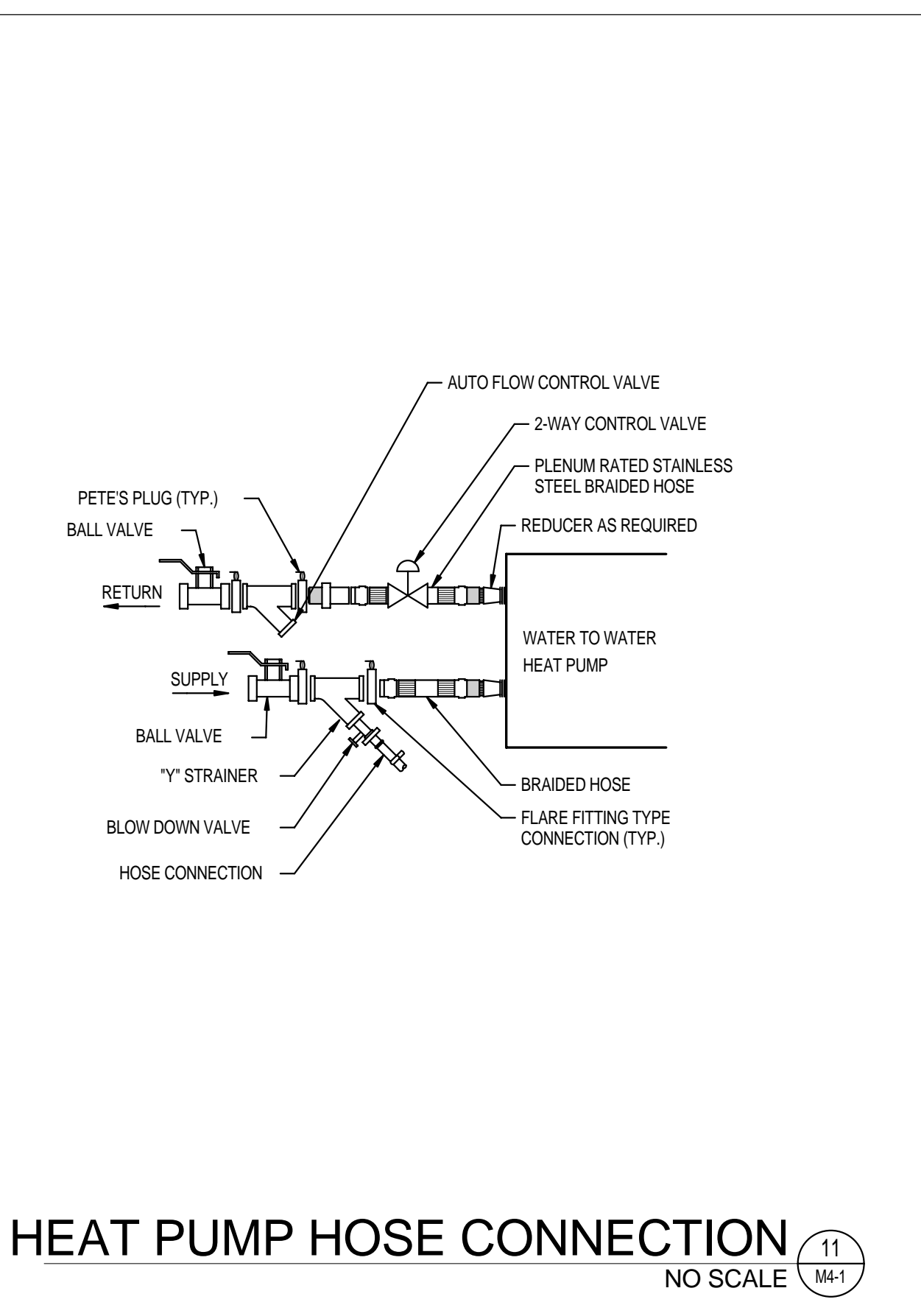

HEAT PUMP HOSE CONNECTION (11) NO SCALE M4-1

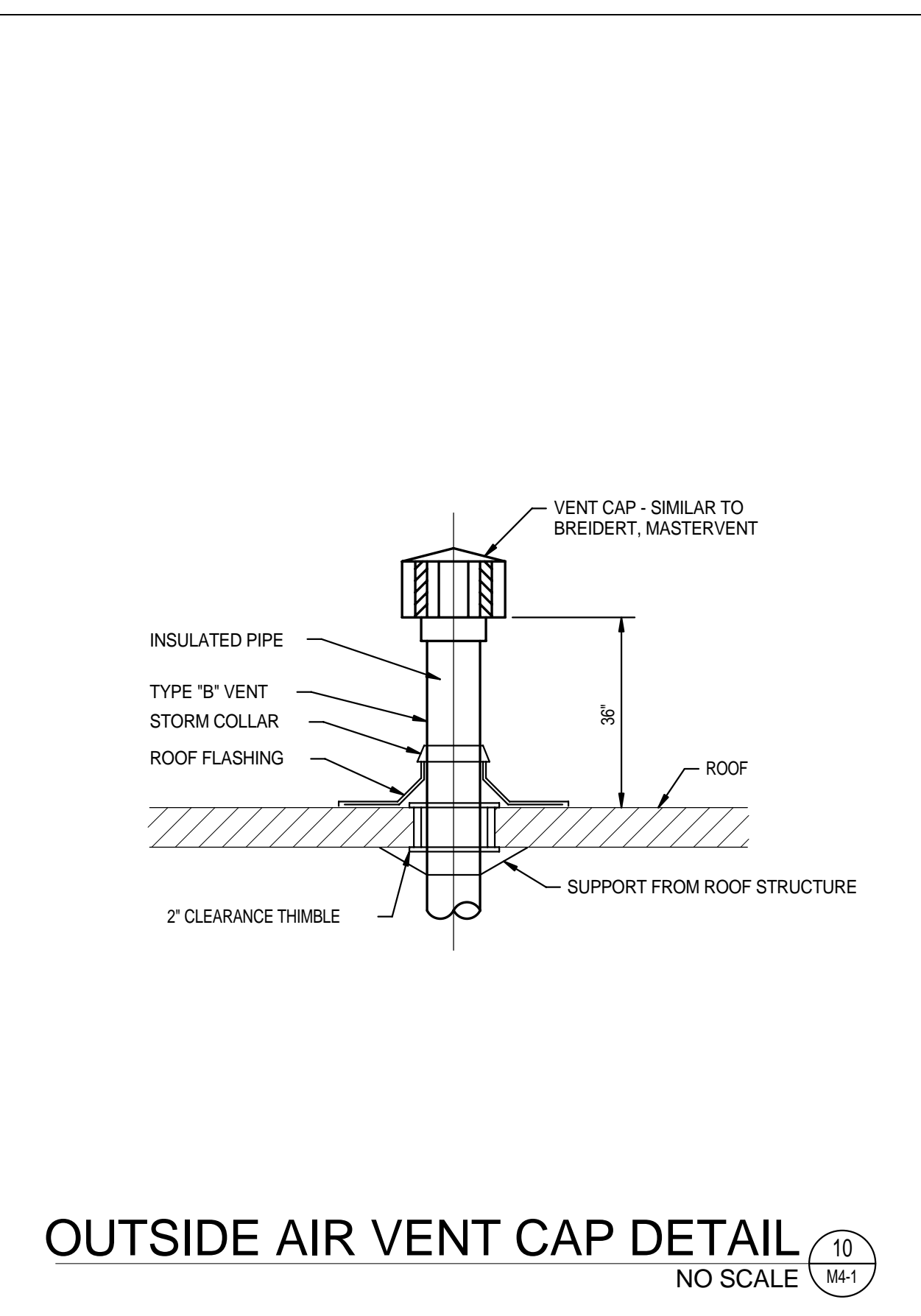

OUTSIDE AIR VENT CAP DETAIL (10) NO SCALE M4-1

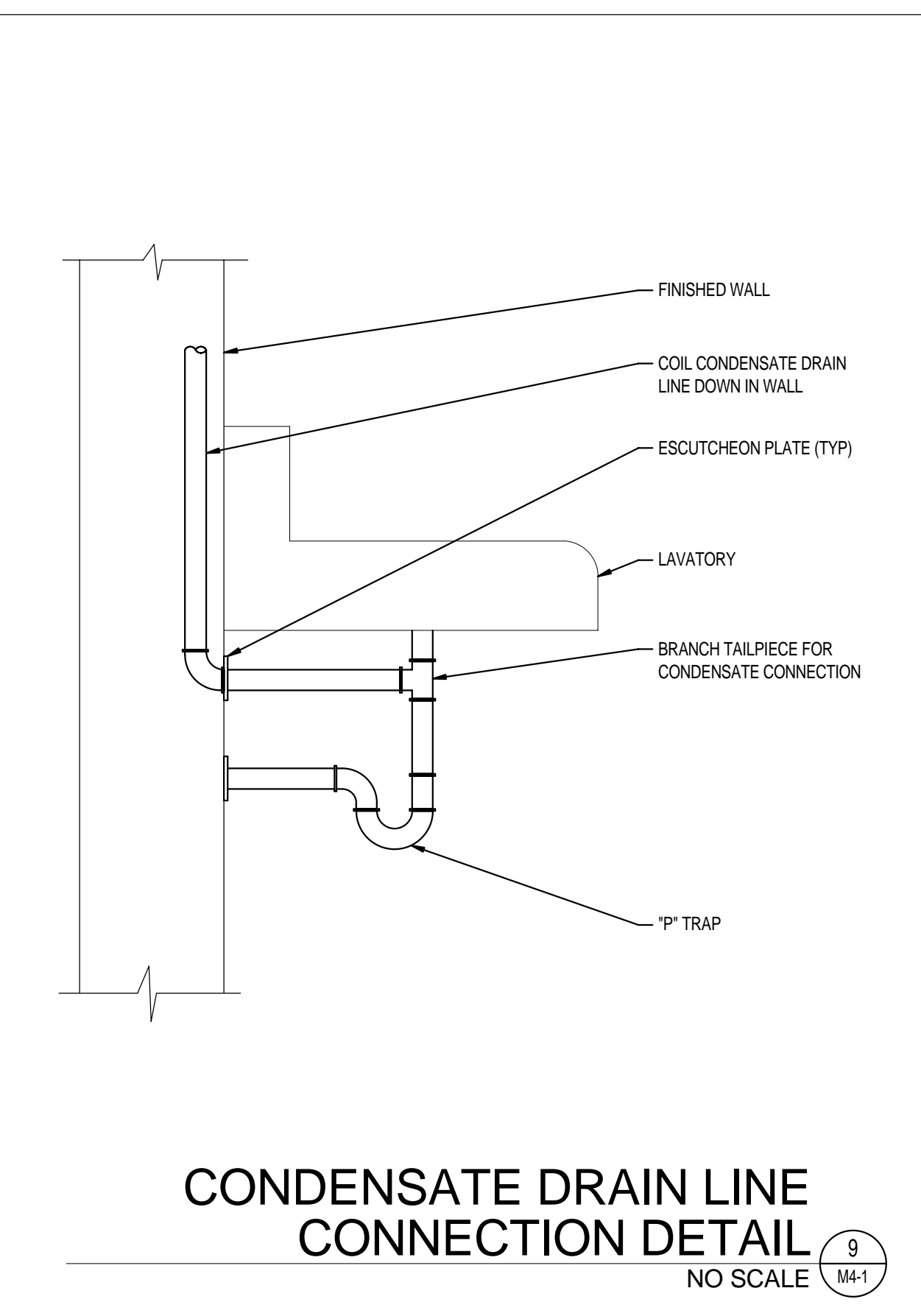

CONDENSATE DRAIN LINE CONNECTION DETAIL (9) NO SCALE M4-1

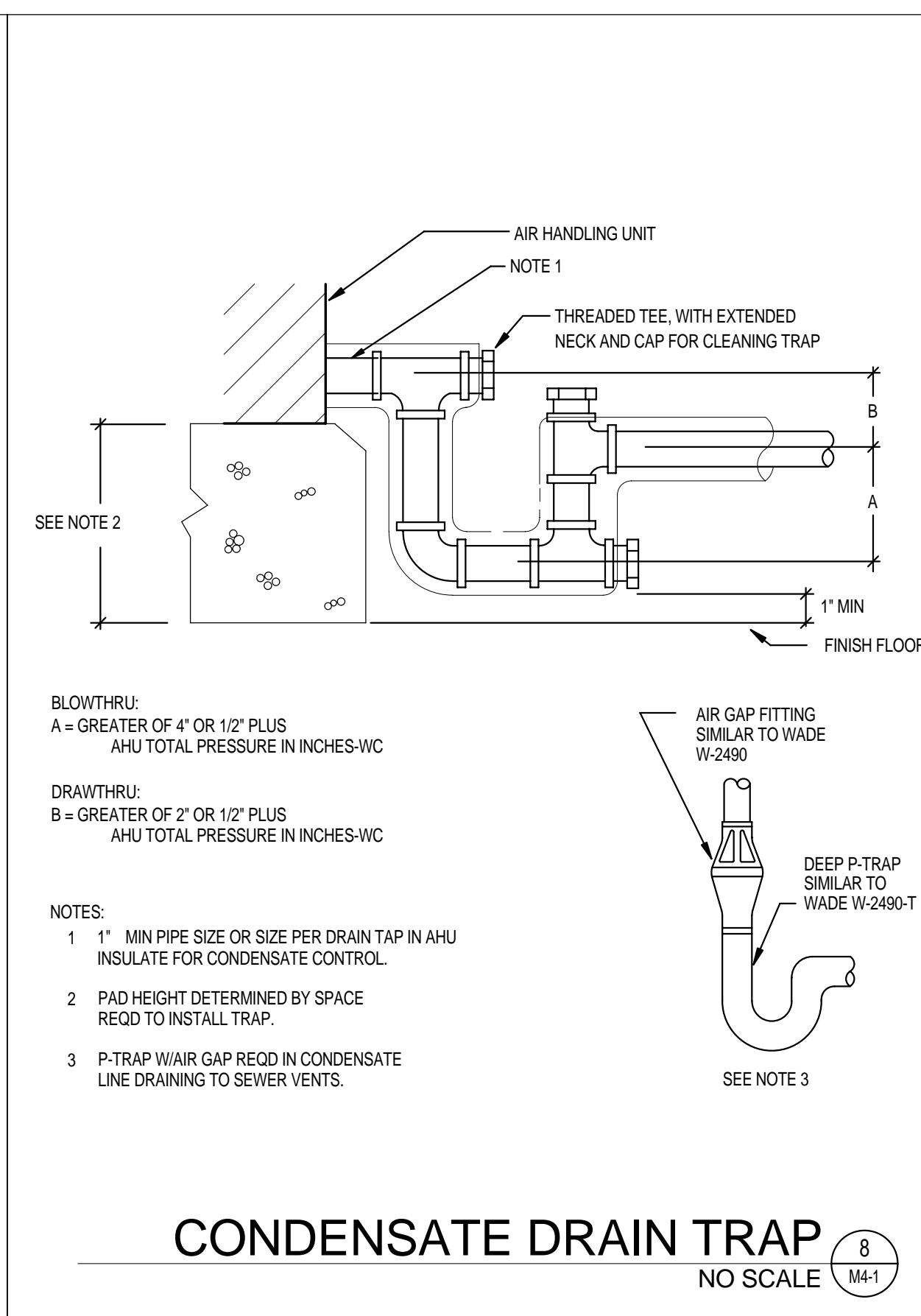

CONDENSATE DRAIN TRAP (8) NO SCALE M4-1

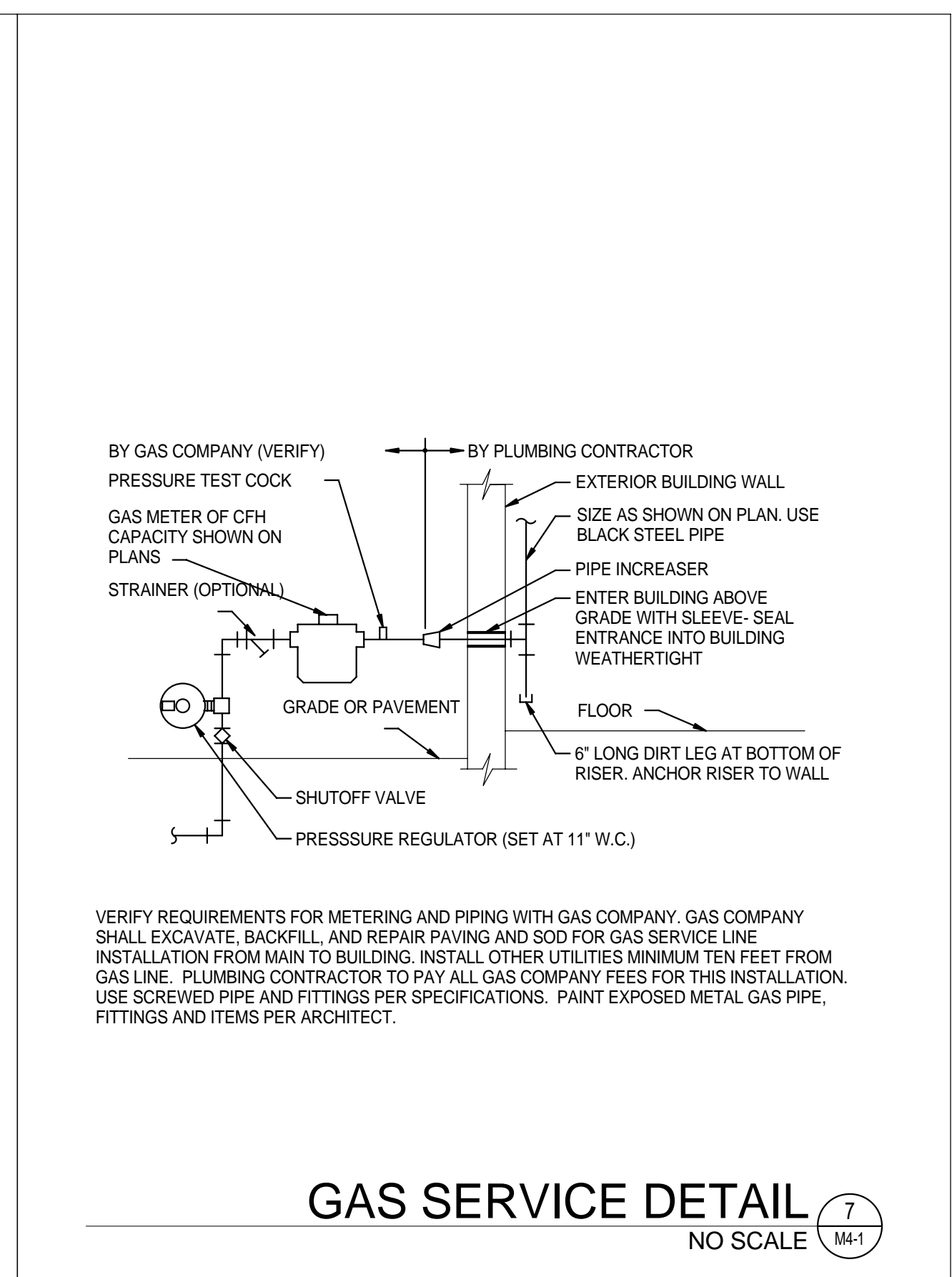

GAS SERVICE DETAIL (7) NO SCALE M4-1

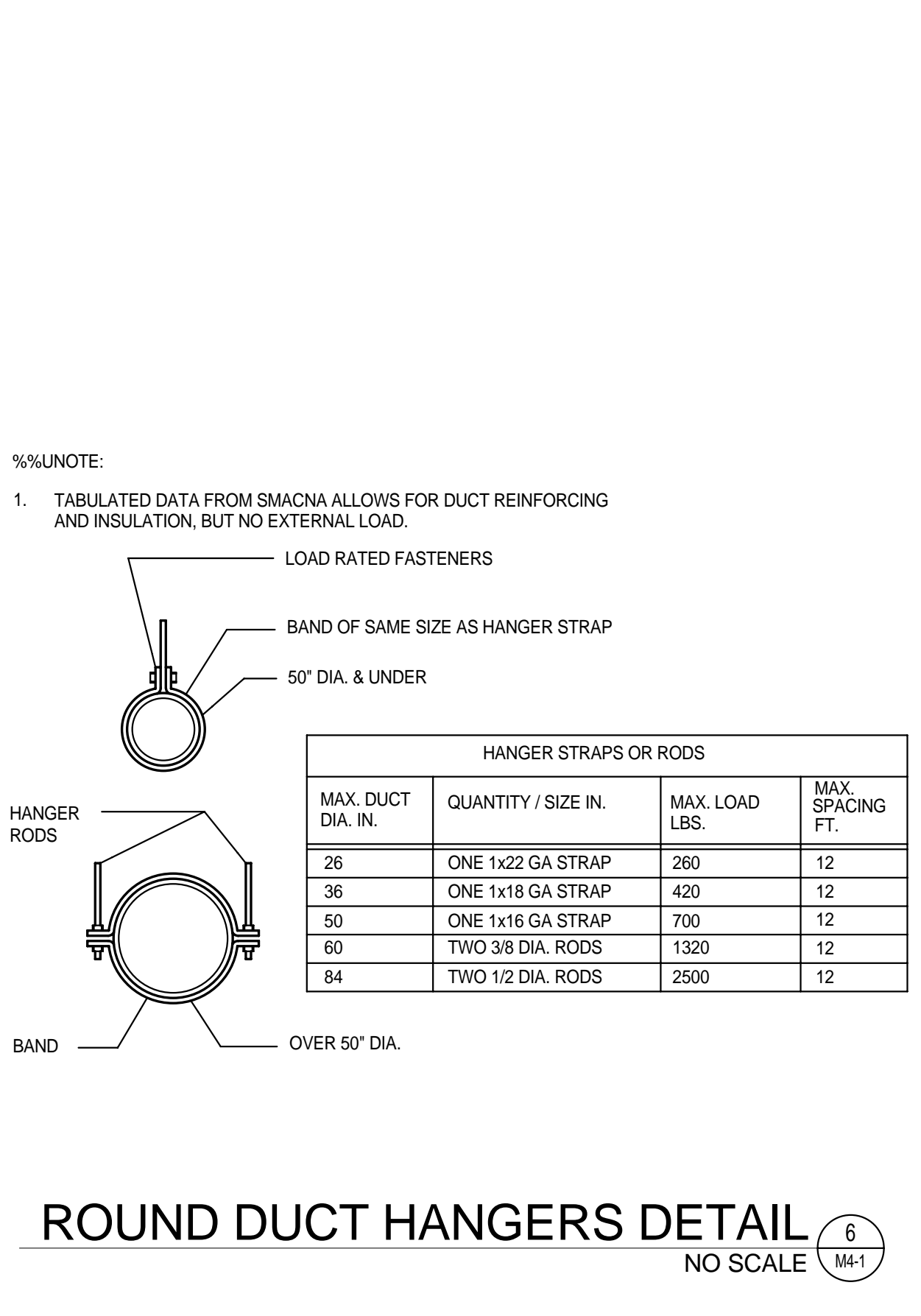

ROUND DUCT HANGERS DETAIL (6) NO SCALE M4-1

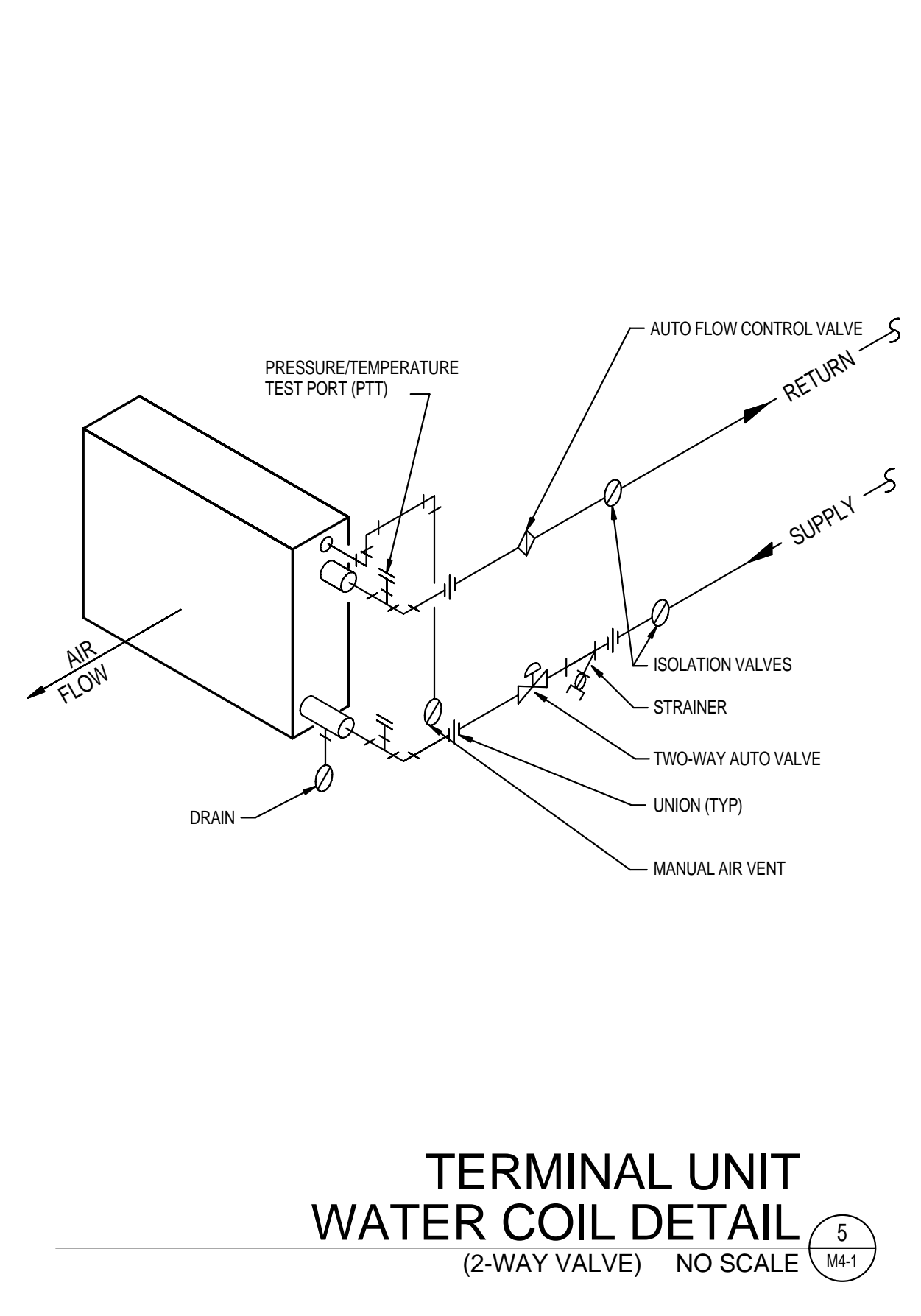

TERMINAL UNIT WATER COIL DETAIL (5) NO SCALE M4-1

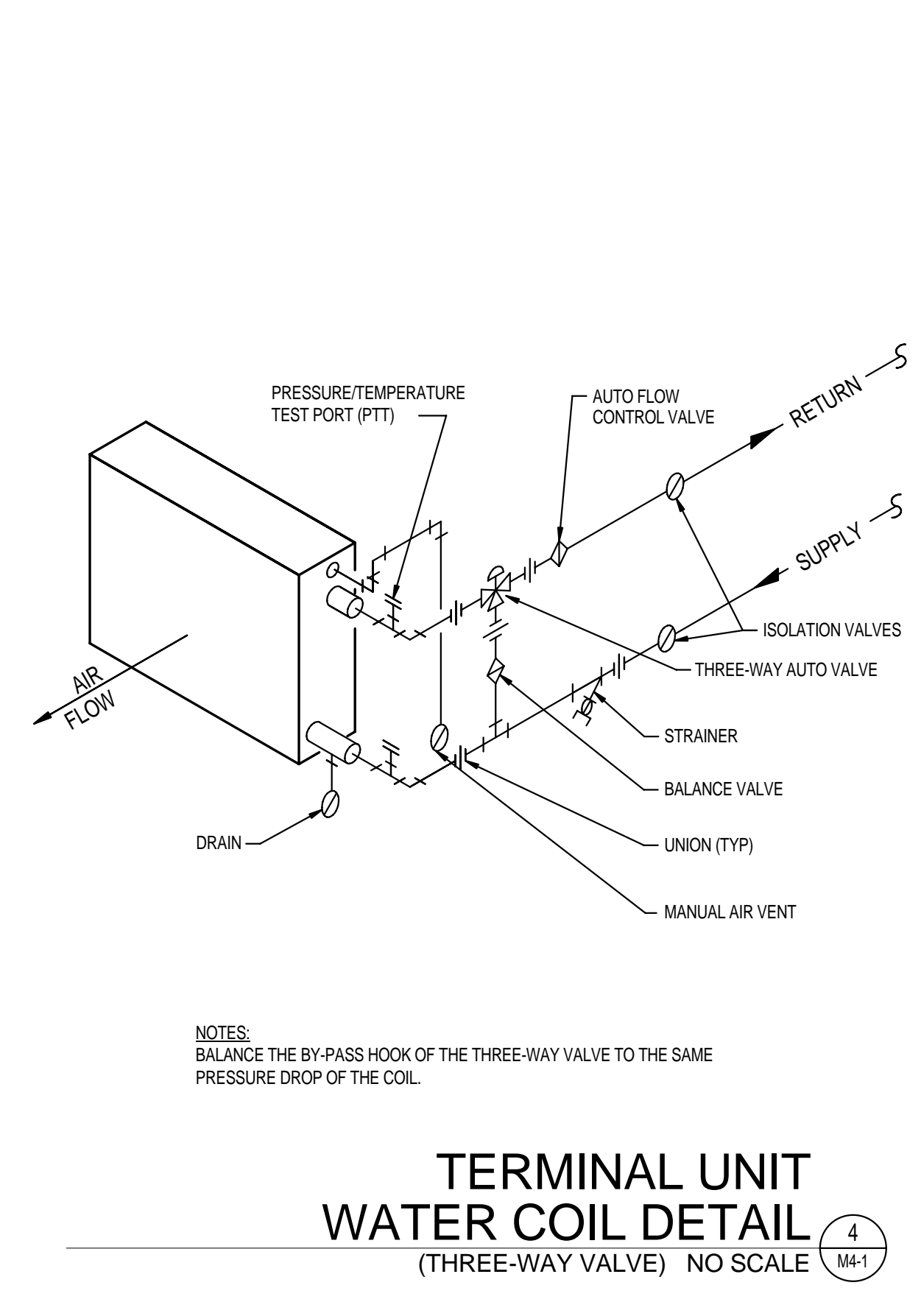

TERMINAL UNIT WATER COIL DETAIL (4) NO SCALE M4-1

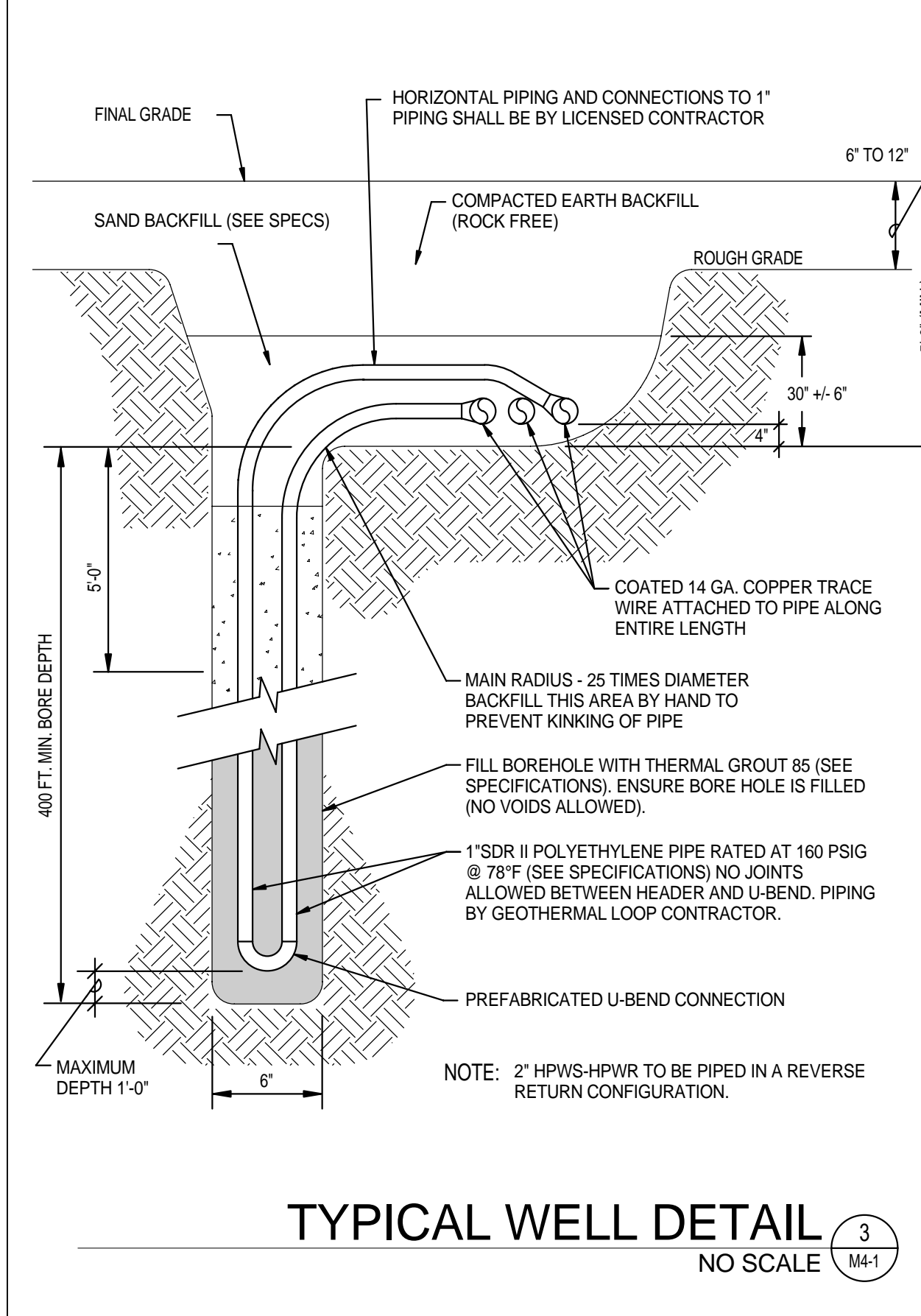

TYPICAL WELL DETAIL (3) NO SCALE M4-1

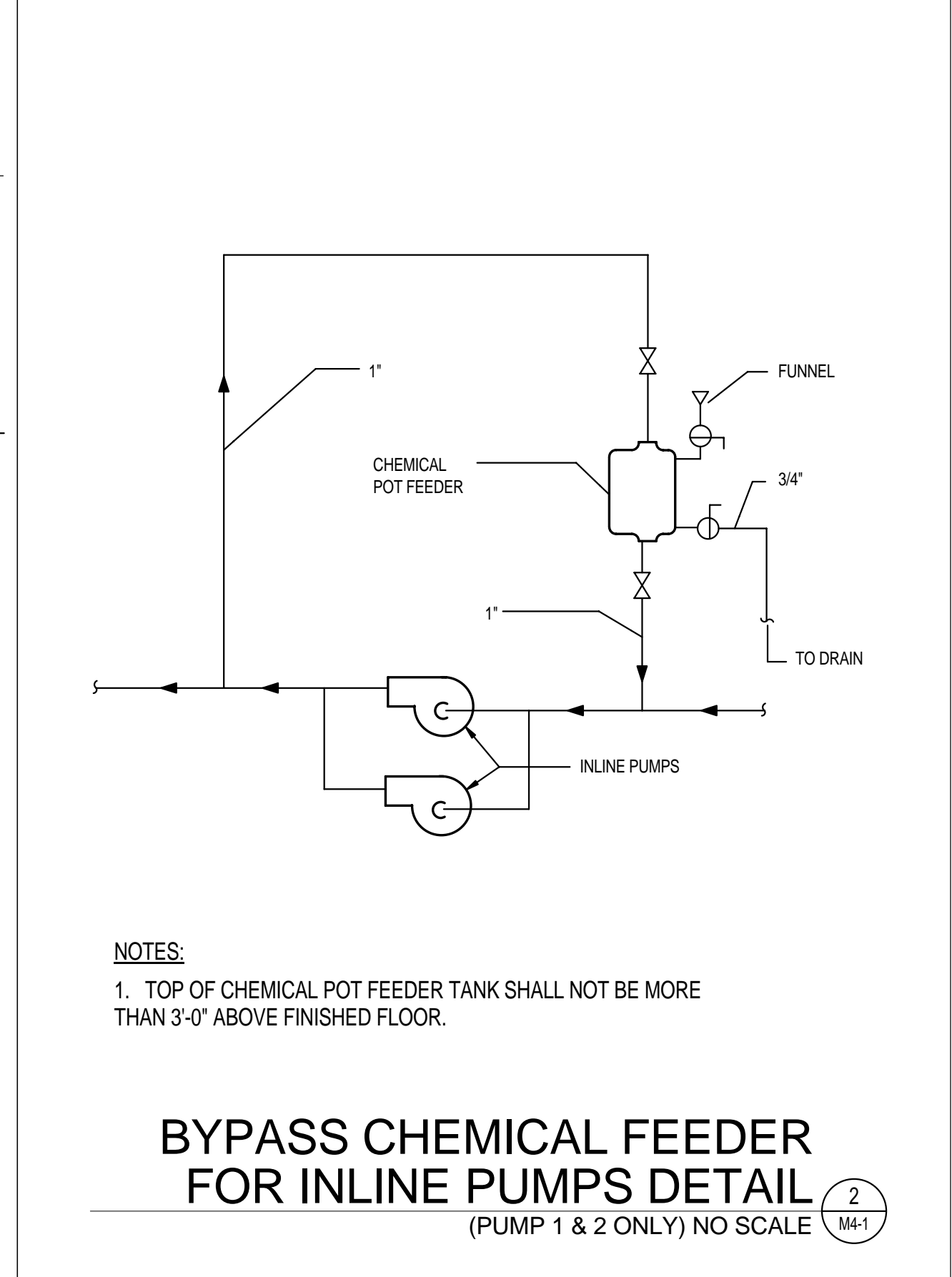

BYPASS CHEMICAL FEEDER FOR INLINE PUMPS DETAIL (2) NO SCALE M4-1

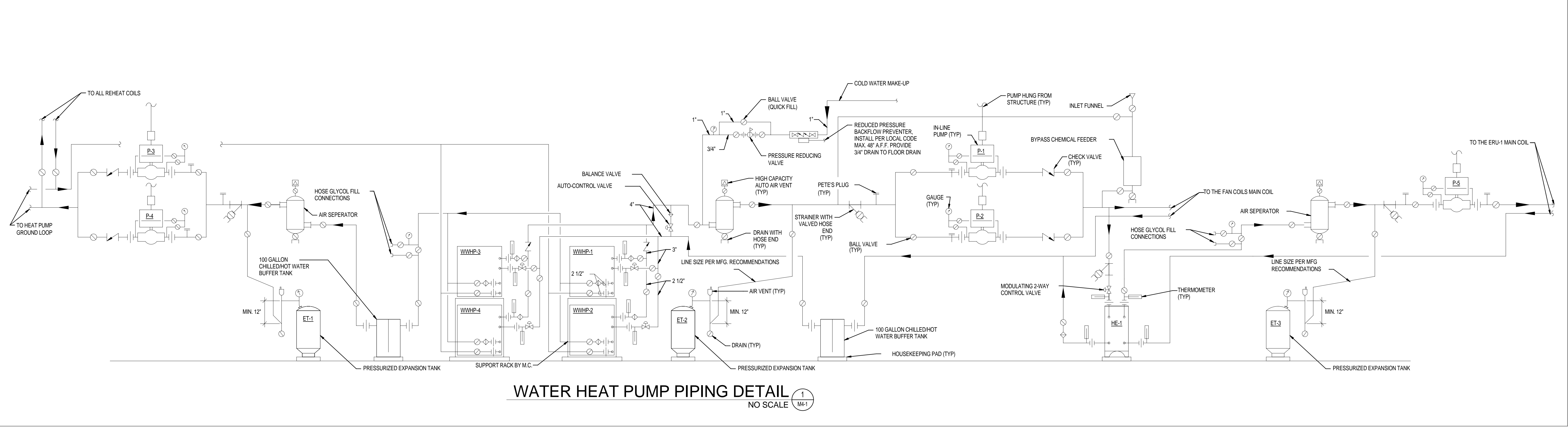

WATER HEAT PUMP PIPING DETAIL (1) NO SCALE M4-1