

NO.	DESCRIPTION	DATE	BY

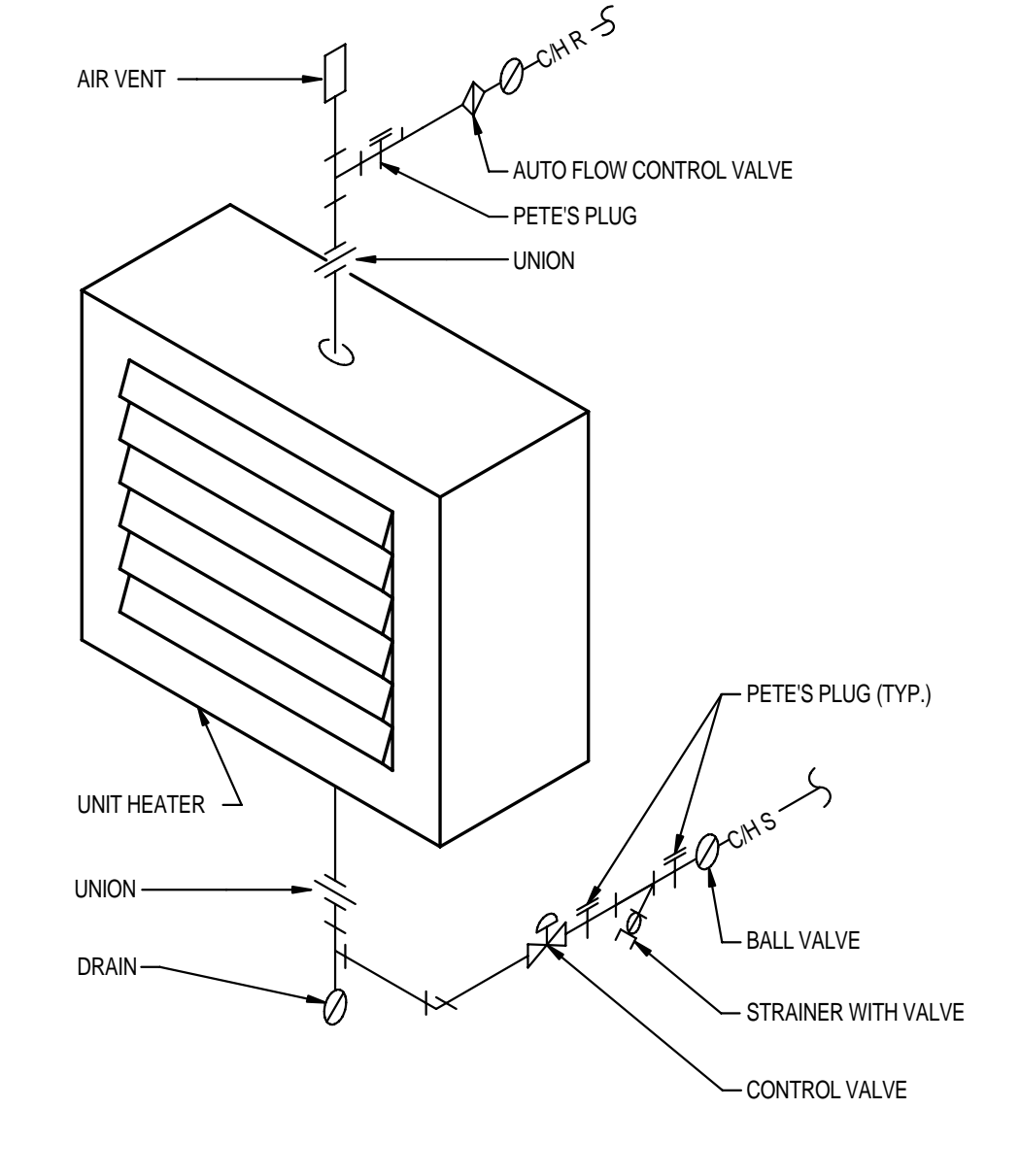

HOT WATER UNIT HEATER DETAIL
NO SCALE (13) M4-0

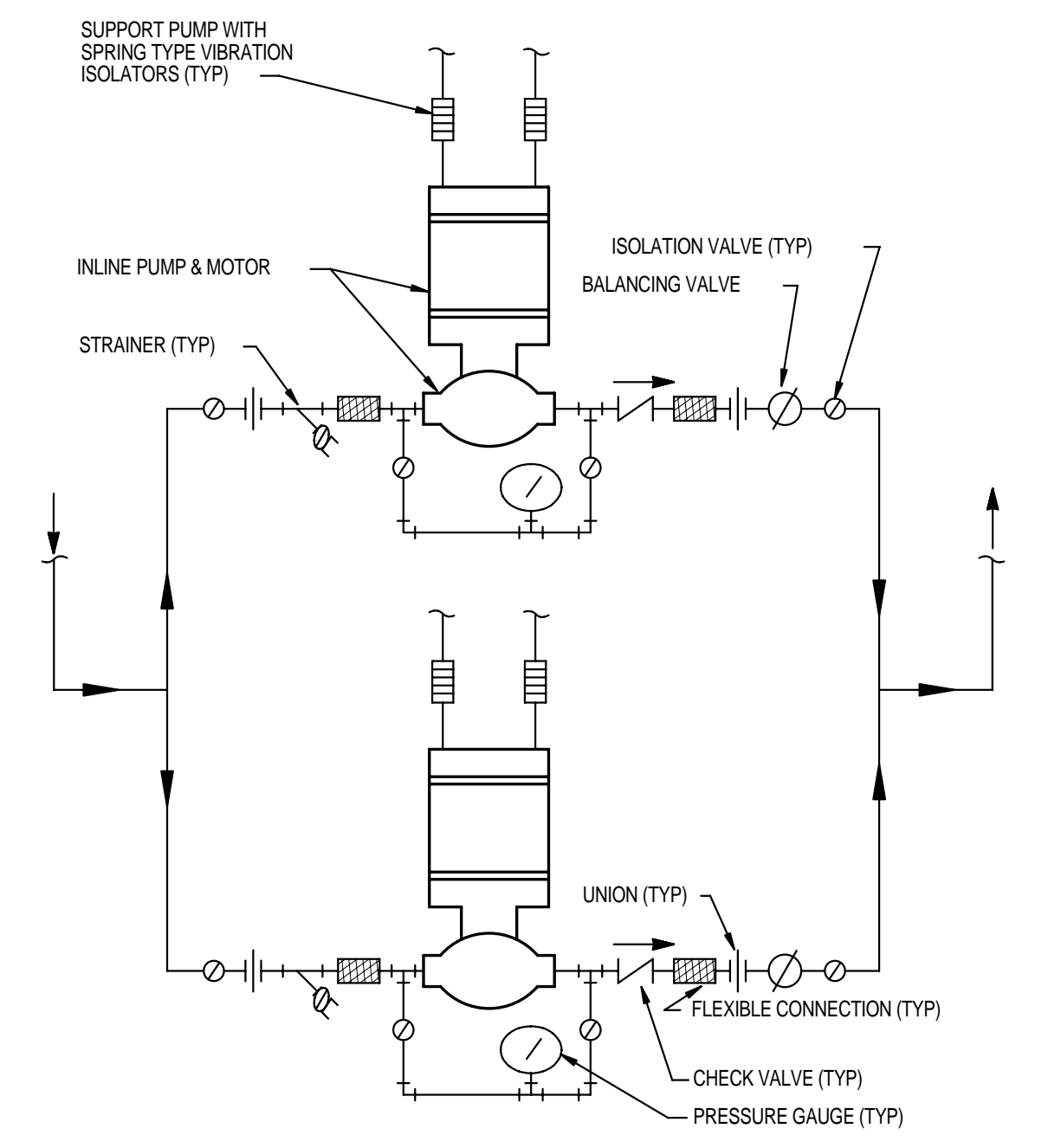

INLINE PUMP DETAIL
NO SCALE (12) M4-0

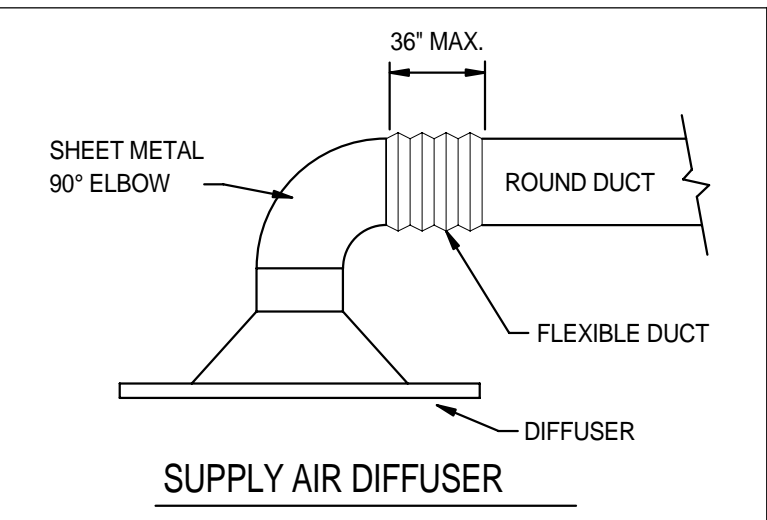

SUPPLY AIR DIFFUSER

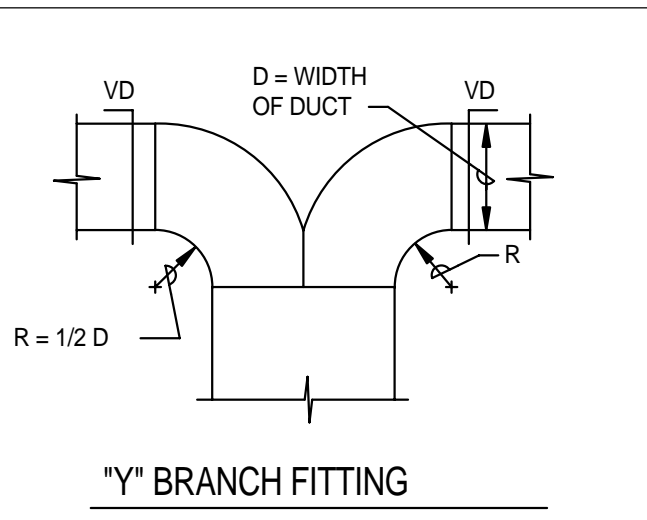

Y BRANCH FITTING

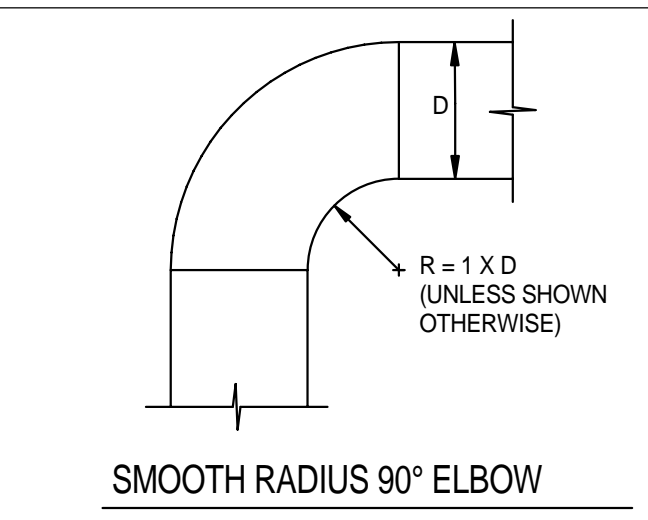

SMOOTH RADIUS 90° ELBOW

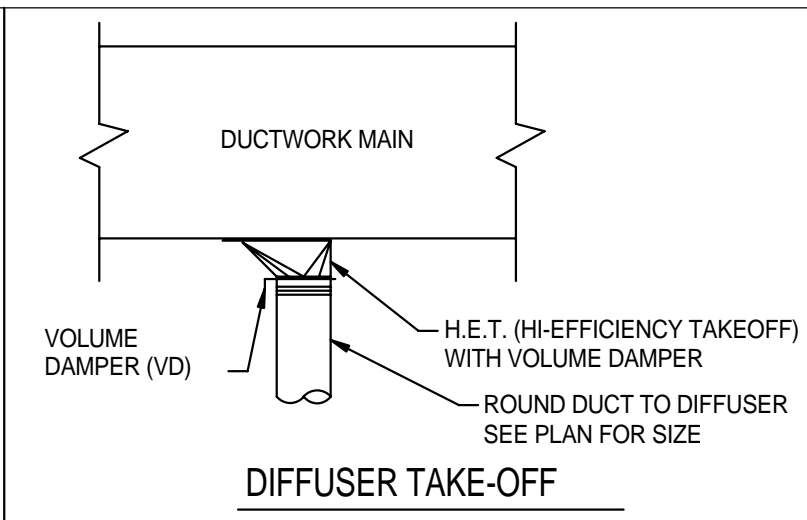

DIFFUSER TAKE-OFF

NOTES:
1. FITTINGS 2" AND LESS DO NOT REQUIRE TURNING VANES.
2. TURNING VANE IS OF THE SAME GAUGE METAL AS THE FITTING.
R = 1/3 W (W NOT LESS THAN 3")
S = 1/3 W
L = 1/3 W

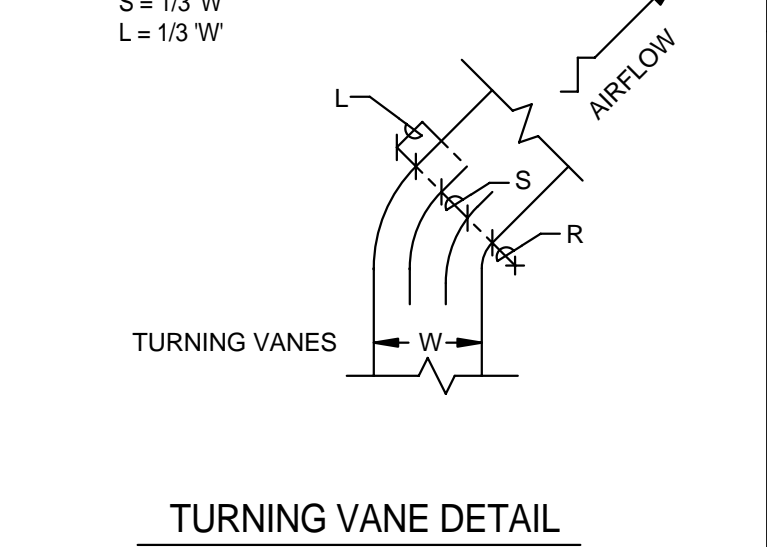

TURNING VANE DETAIL

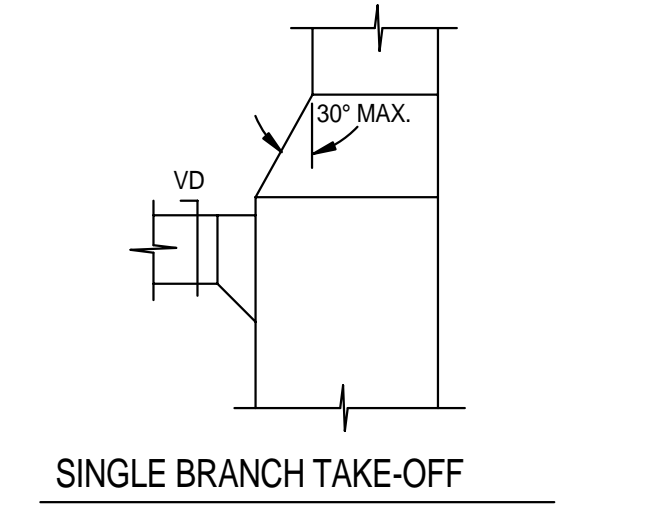

SINGLE BRANCH TAKE-OFF

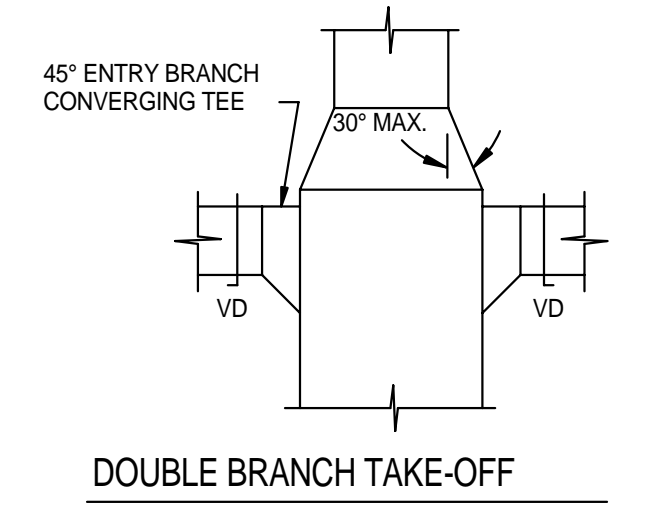

DOUBLE BRANCH TAKE-OFF

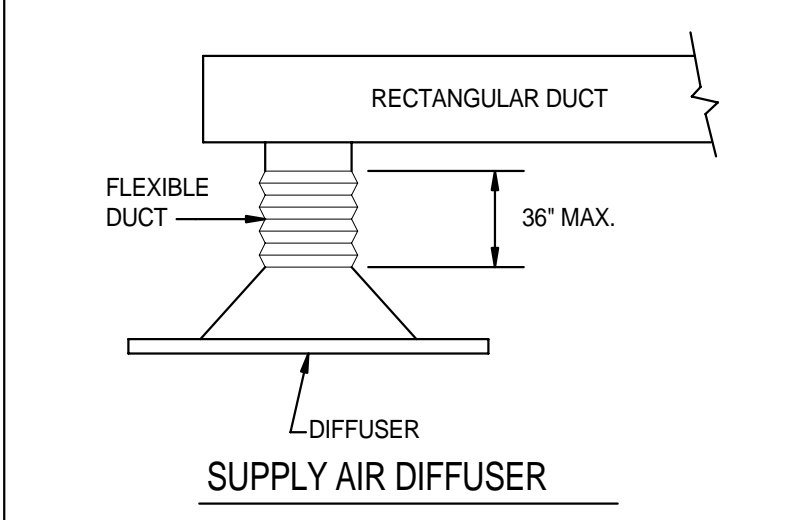

SUPPLY AIR DIFFUSER

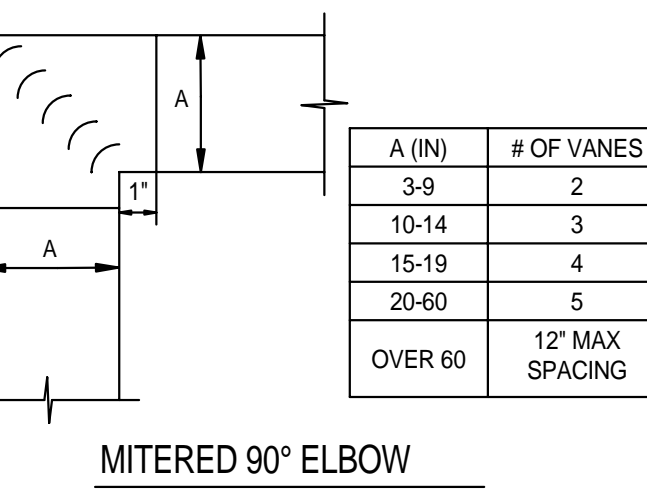

MITERED 90° ELBOW

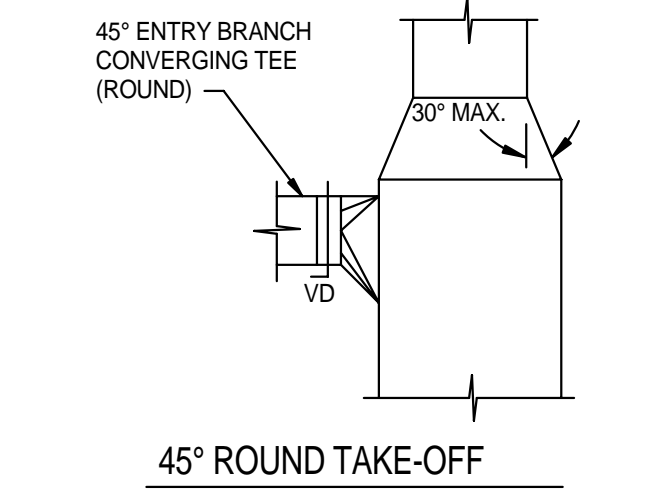

45° ROUND TAKE-OFF

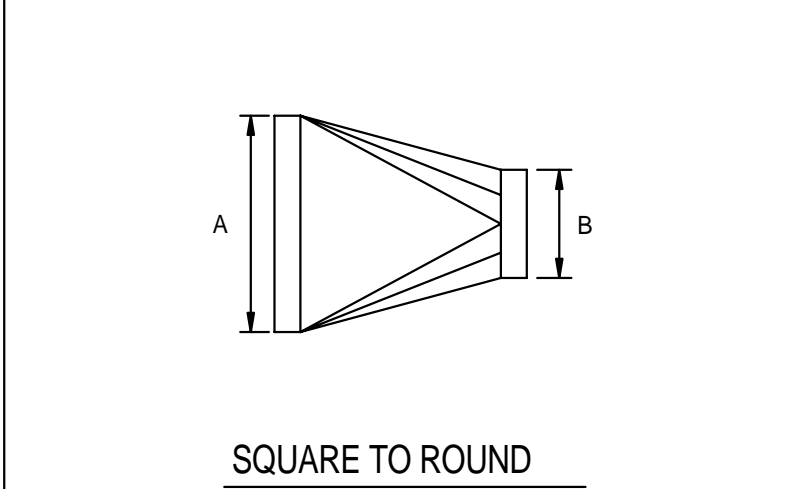

SQUARE TO ROUND

DUCT FITTING DETAILS
NO SCALE (11) M4-0

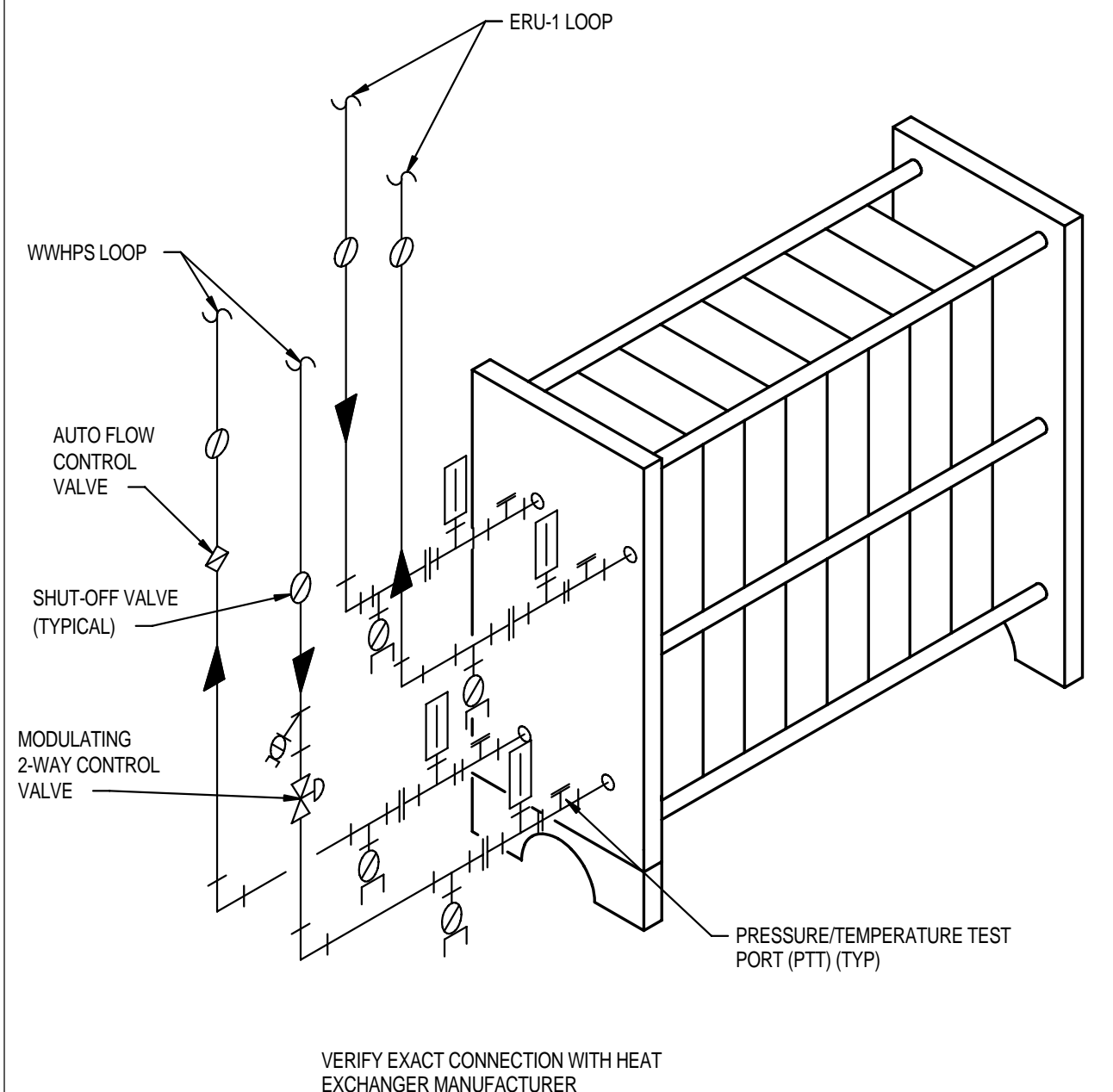

WATER TO WATER HEAT EXCHANGER DETAIL
NO SCALE (10) M4-0

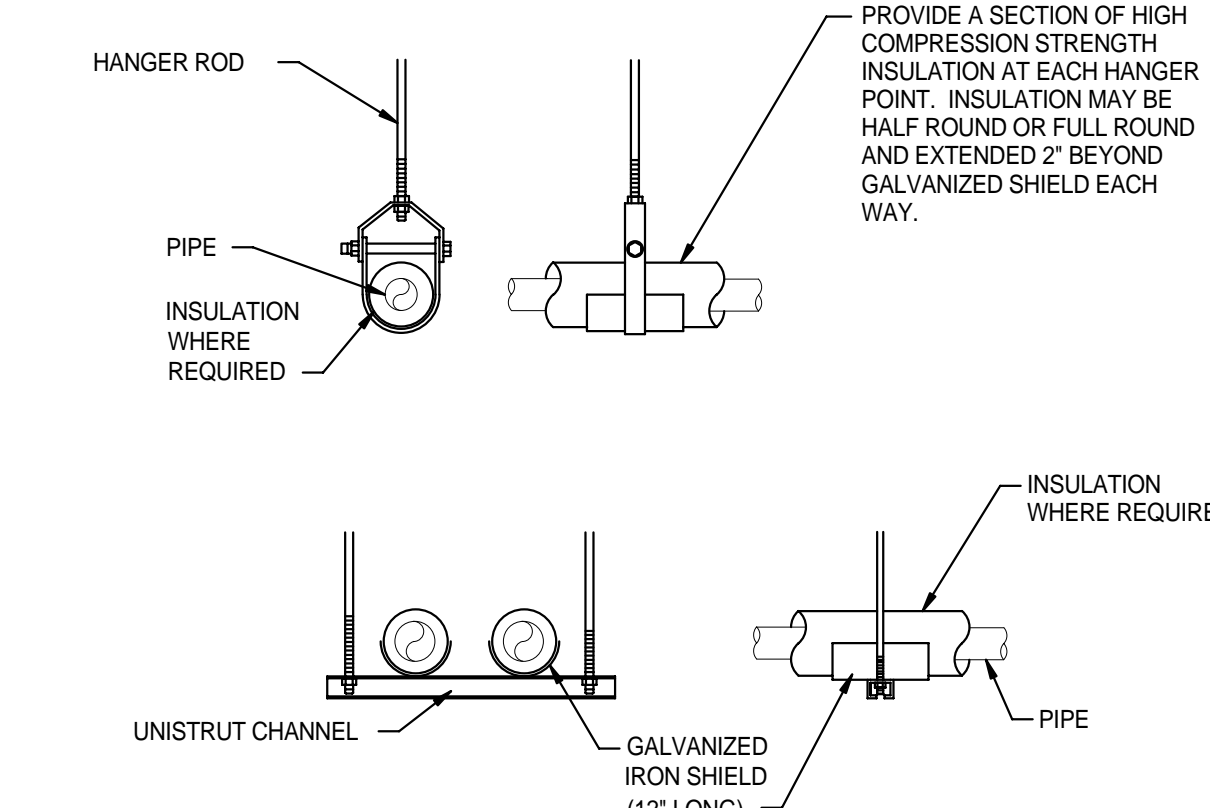

PIPE HANGERS DETAIL
NO SCALE (9) M4-0

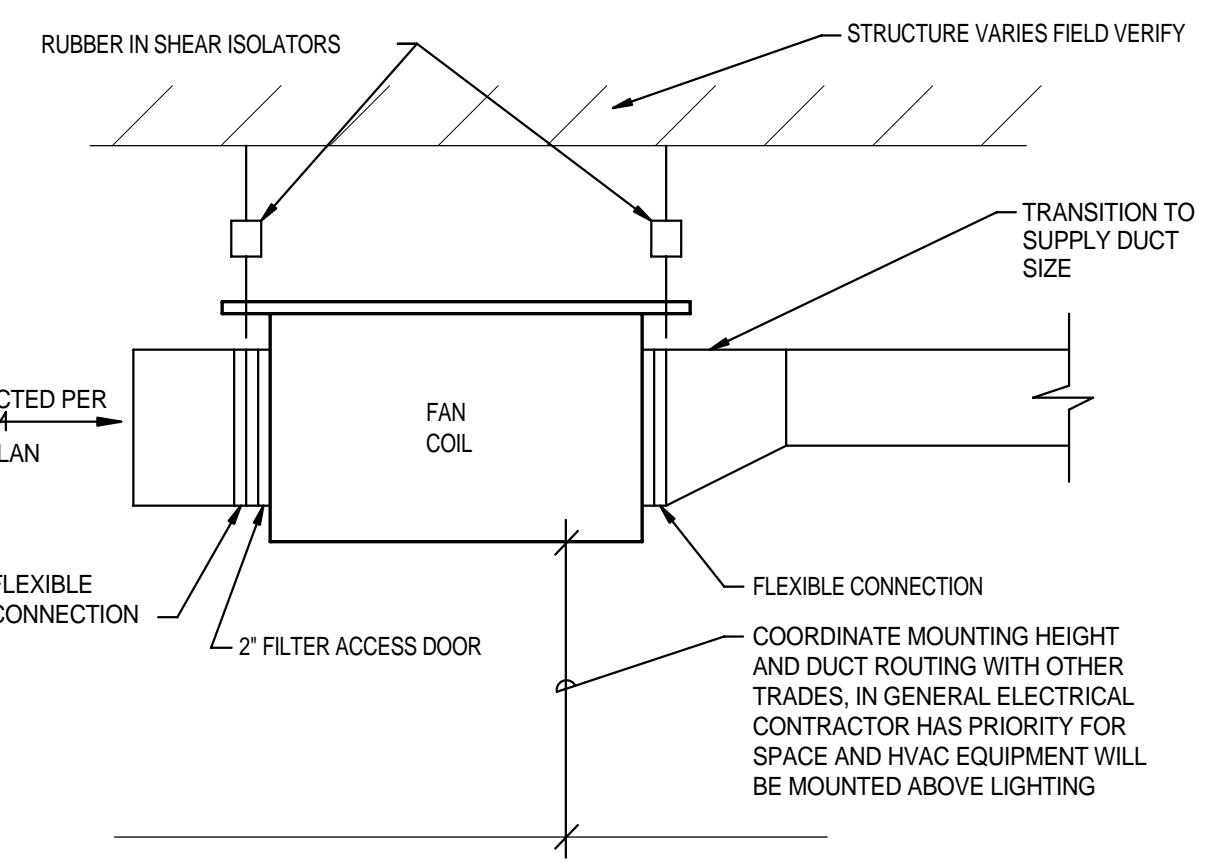

FAN COIL MOUNTING DETAIL
NO SCALE (8) M4-0

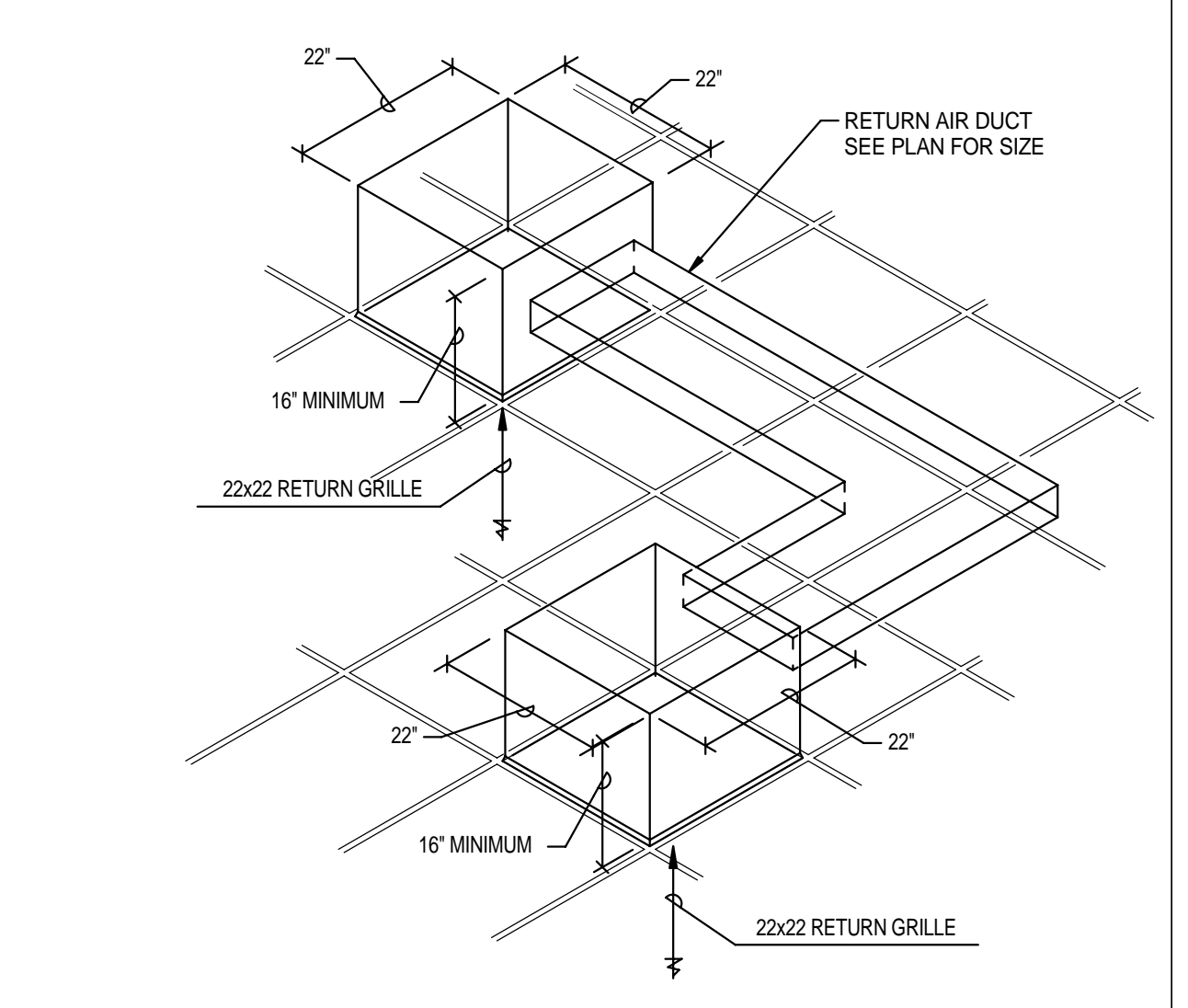

TRANSFER GRILLE CONNECTION DETAIL
NO SCALE (7) M4-0

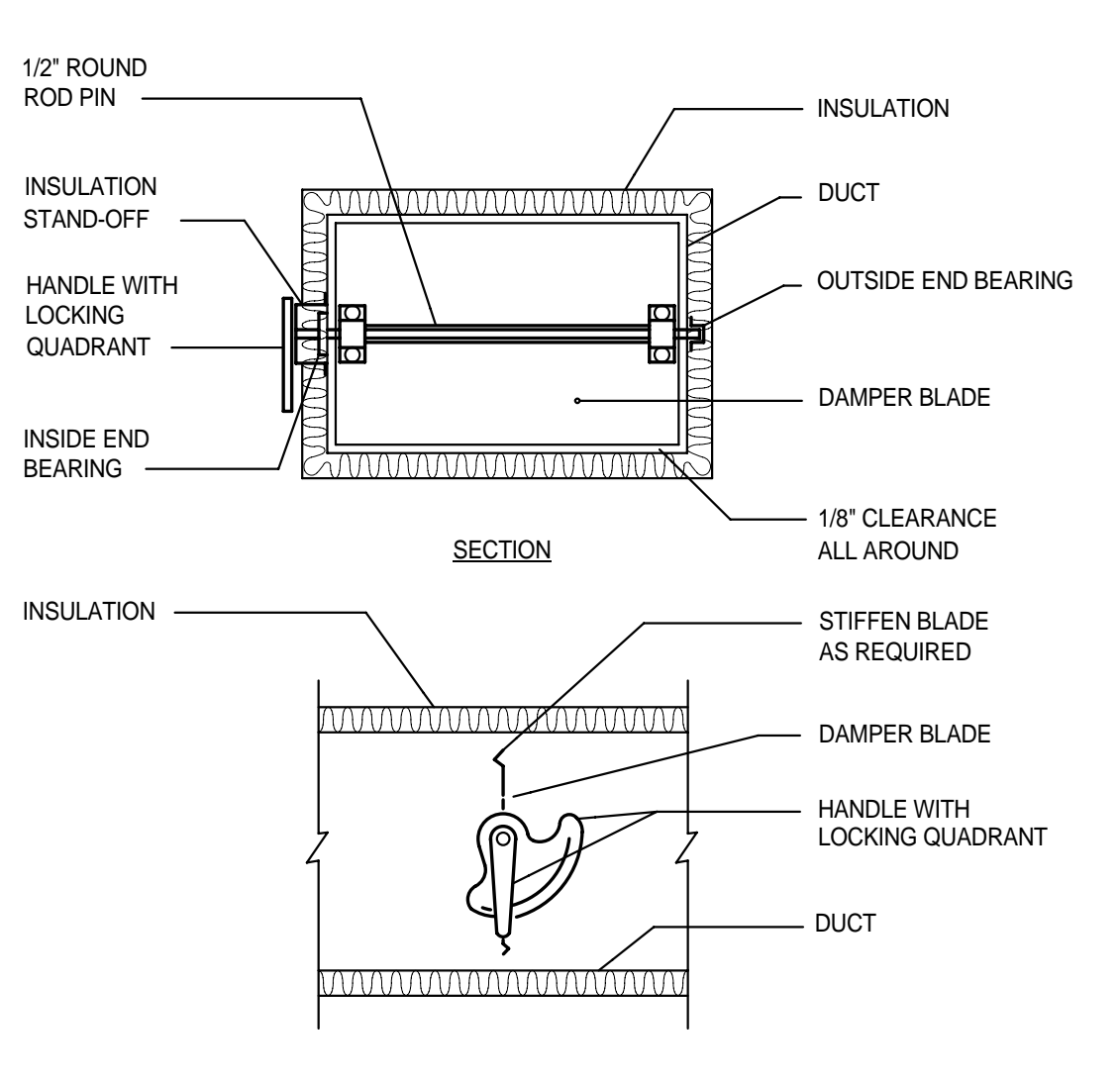

VOLUME DAMPER DETAIL
NO SCALE (6) M4-0

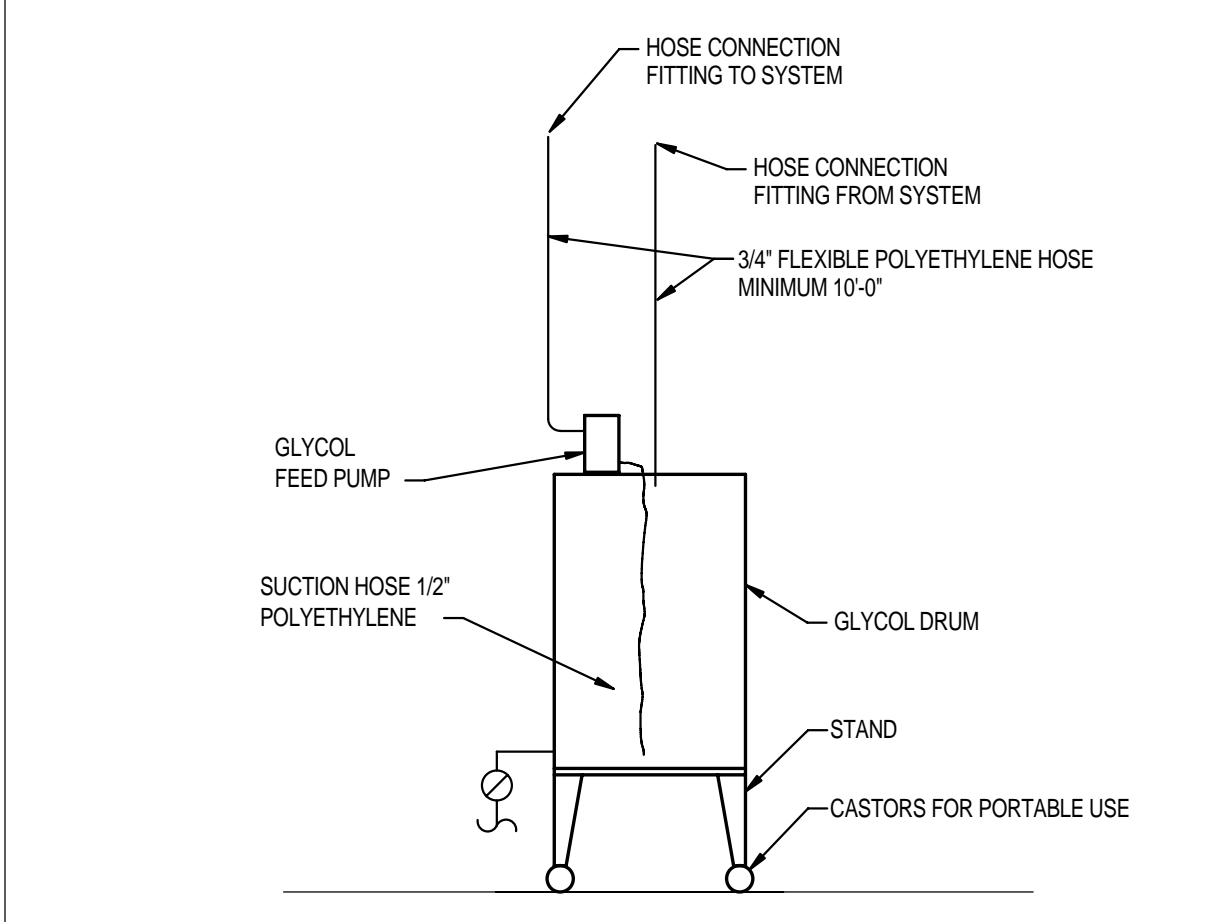

PORTABLE GLYCOL FEED TANK DETAIL
NO SCALE (5) M4-0

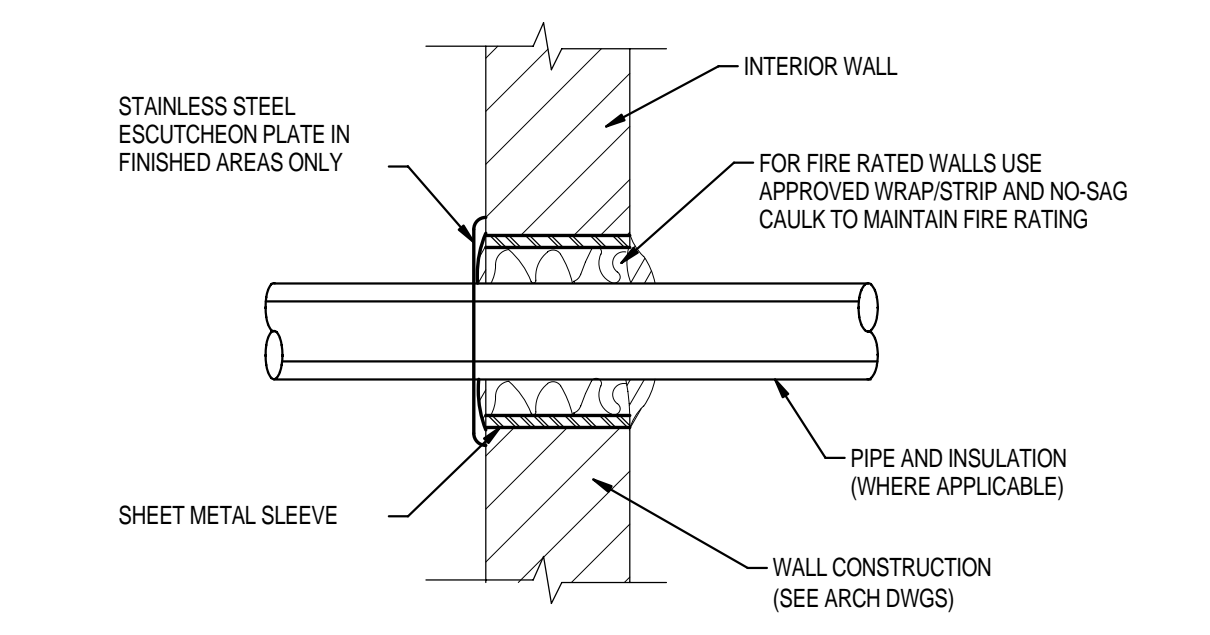

RATED WALL PENETRATION DETAIL
NO SCALE (4) M4-0

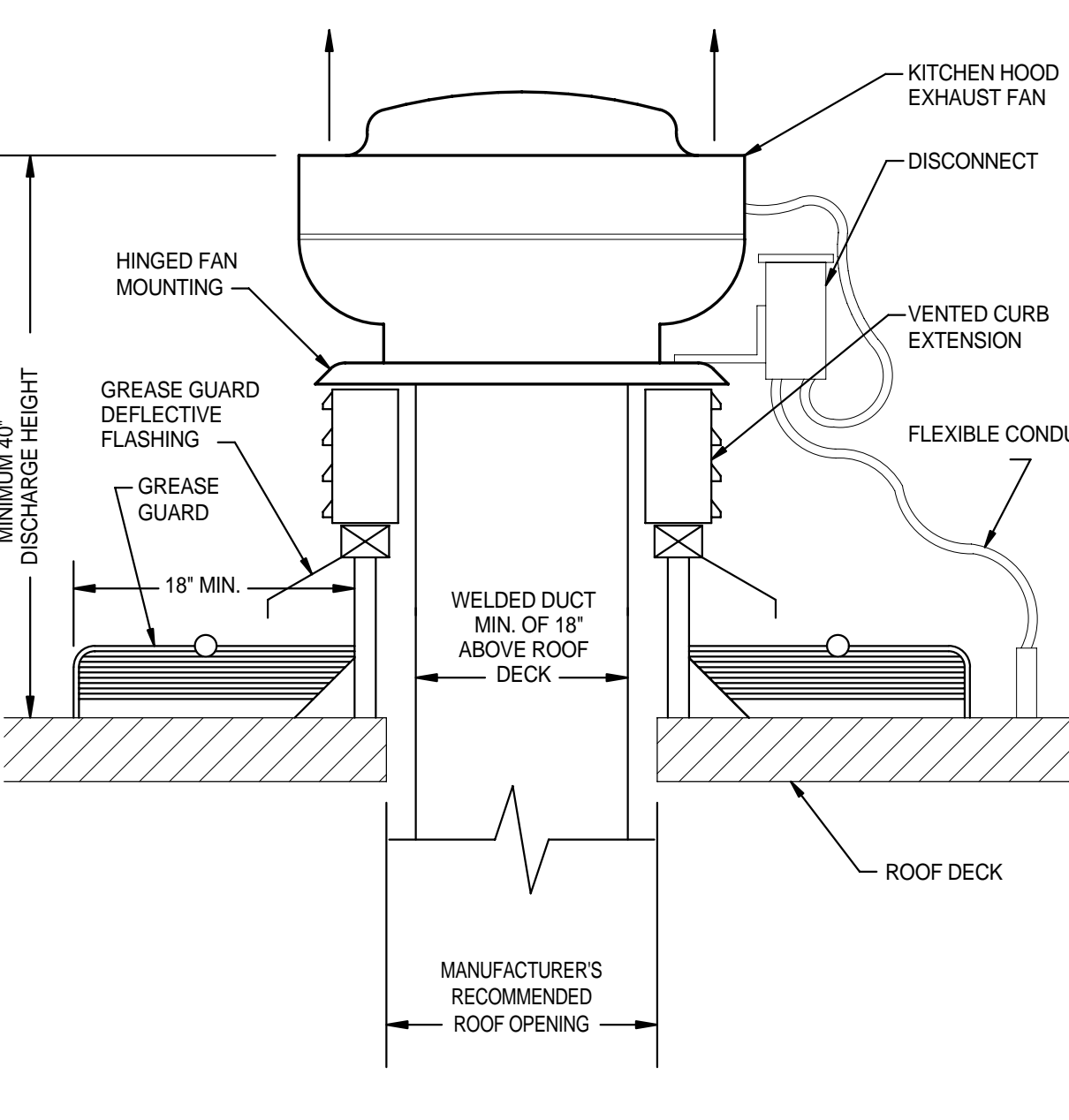

KITCHEN HOOD EXHAUST FAN DETAIL
NO SCALE (3) M4-0

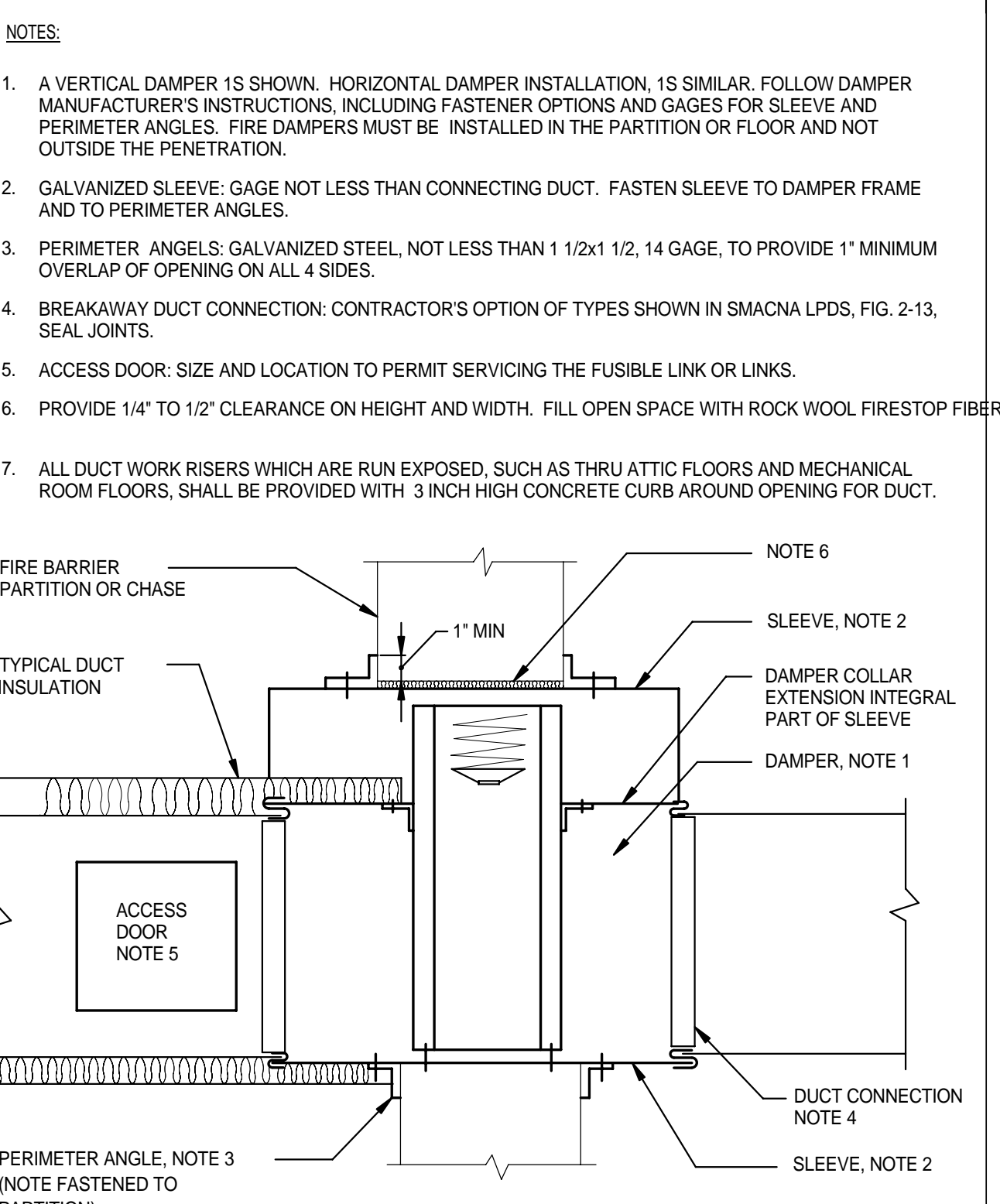

FIRE DAMPER INSTALLATION DETAIL
NO SCALE (2) M4-0

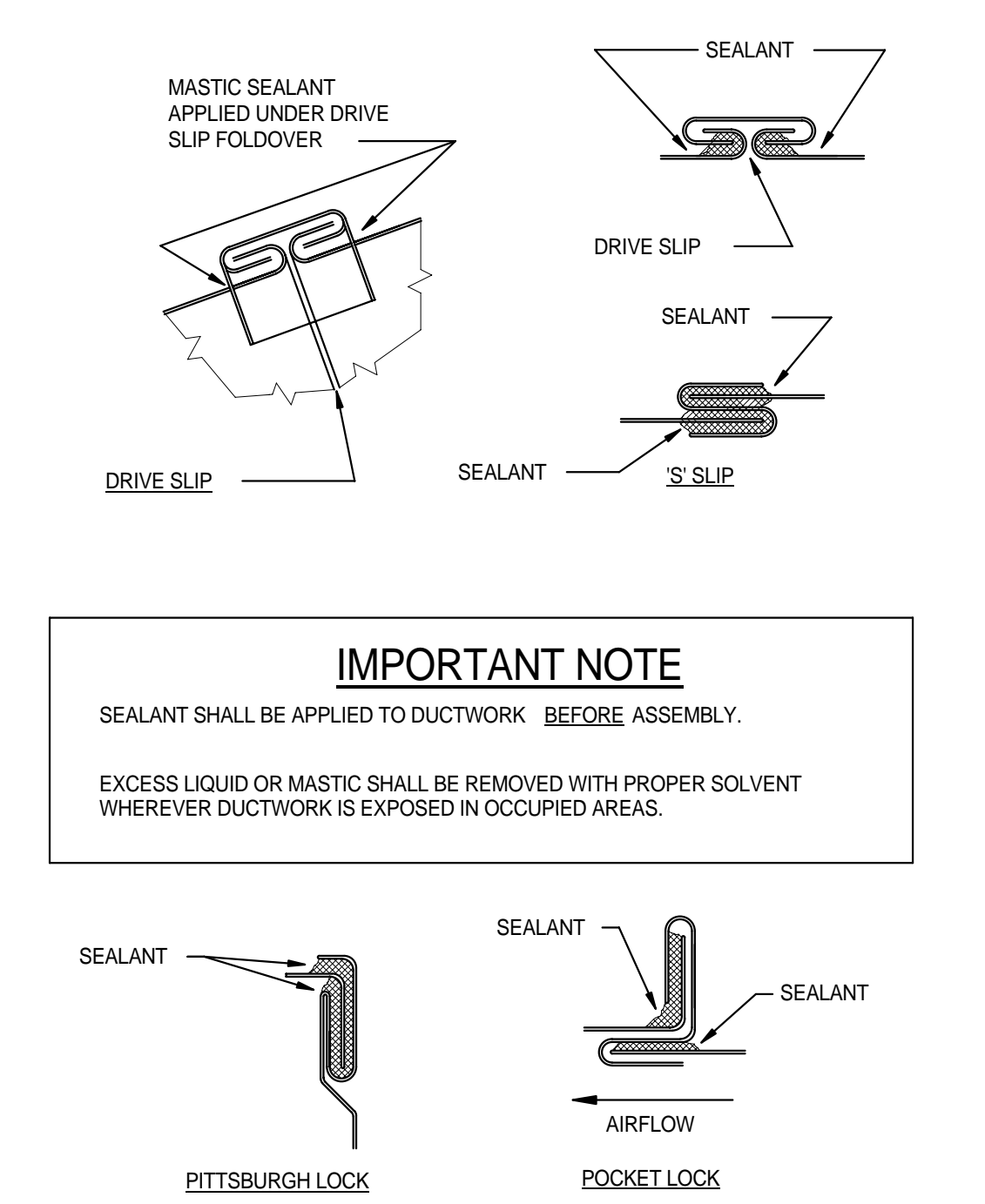

DUCTWORK SEALANT DETAIL
NO SCALE (1) M4-0

