

1 Baptistry Plan - Post Locations
1/4" = 1'-0"

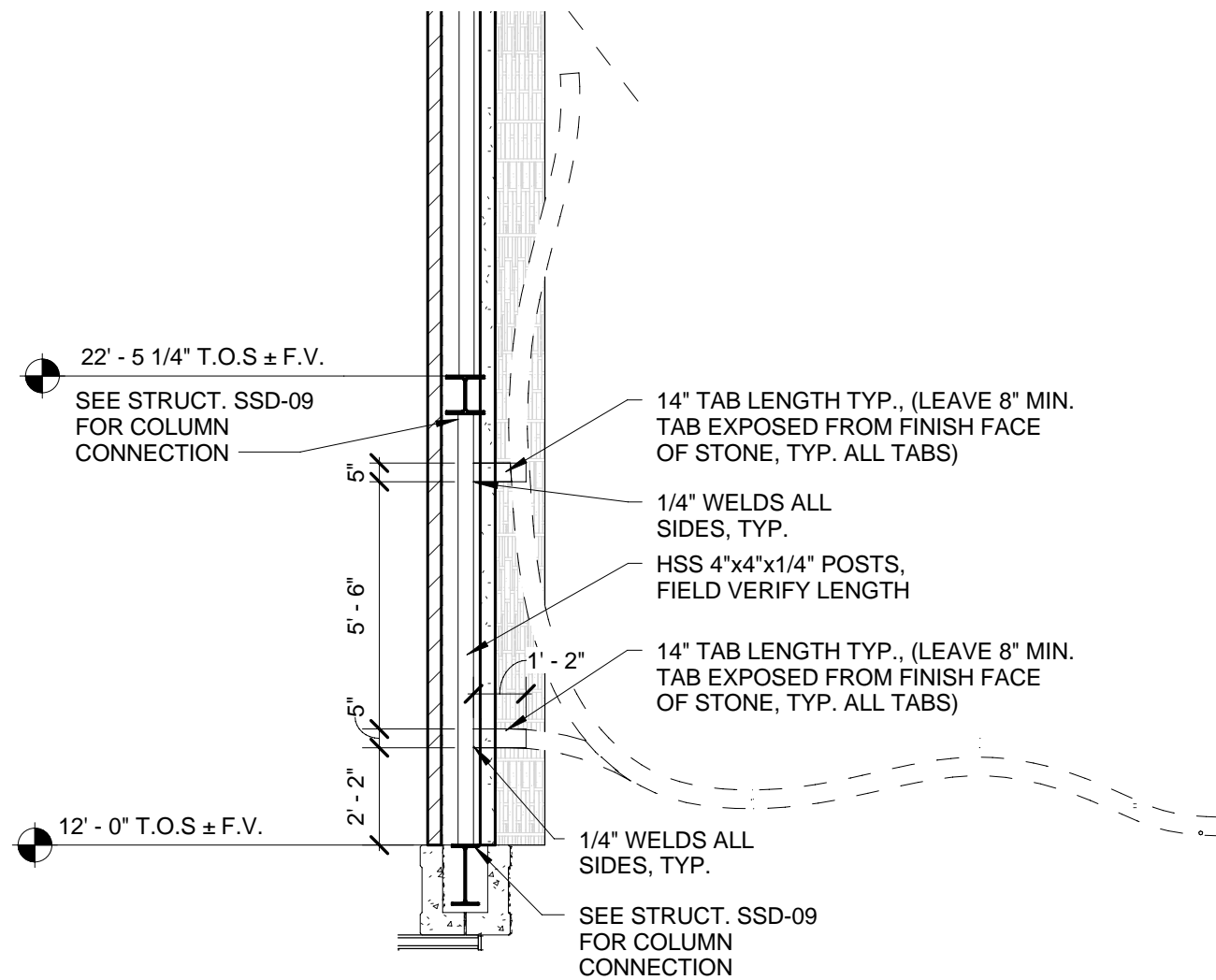

BCDM PROJECT NO. 0364-07	SUPPLEMENTAL DRAWING	ATTACHMENT
DATE: 23 APRIL 2010		ASD-17



② Copy of Baptistry Rib - B
1/4" = 1'-0"

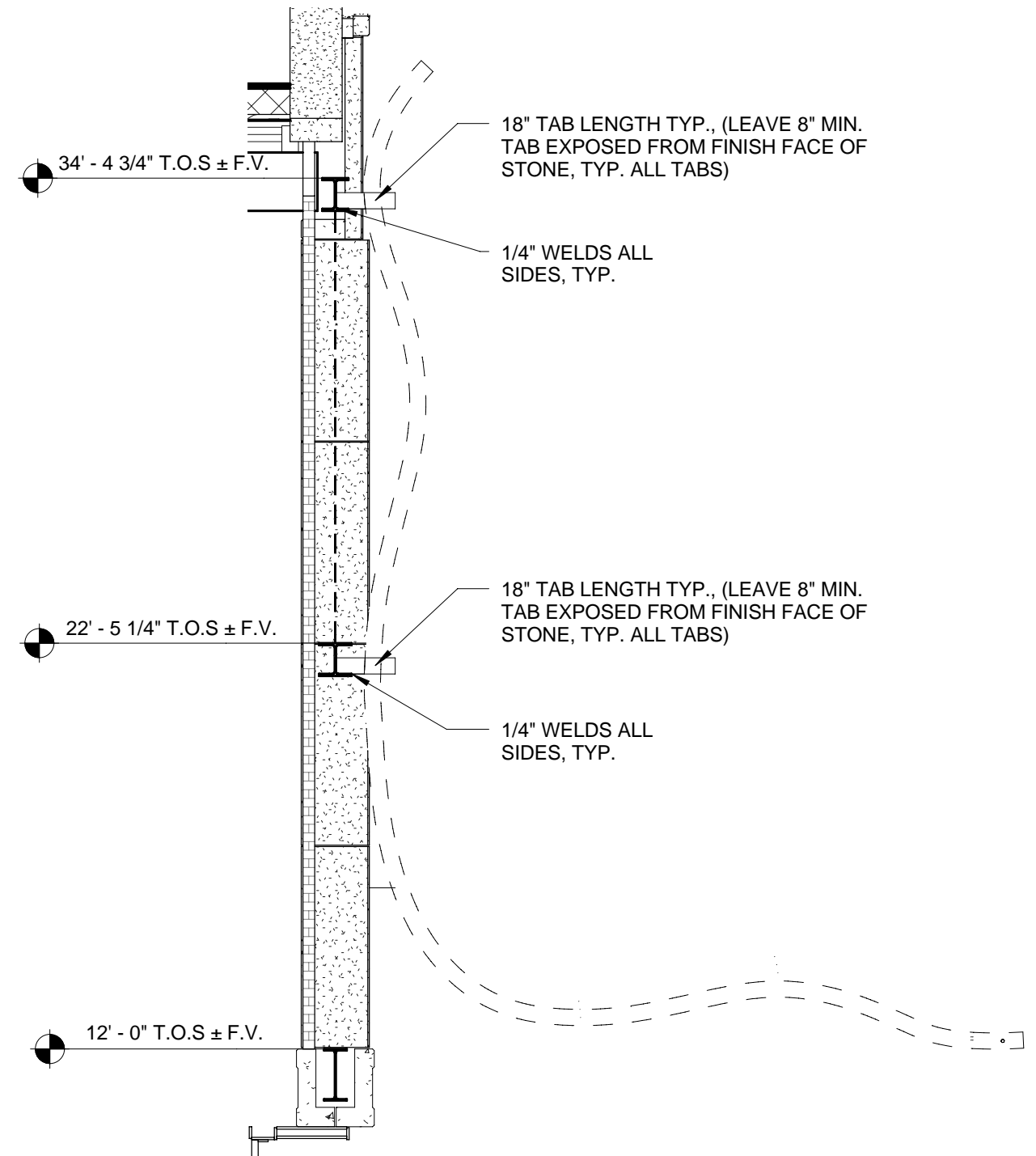

① Copy of Baptistry Rib - A
1/4" = 1'-0"



BCDM PROJ. NO. 0364-07	SUPPLEMENTAL DRAWING	ATTACHMENT
DATE: 23 APRIL 2010		ASD-19

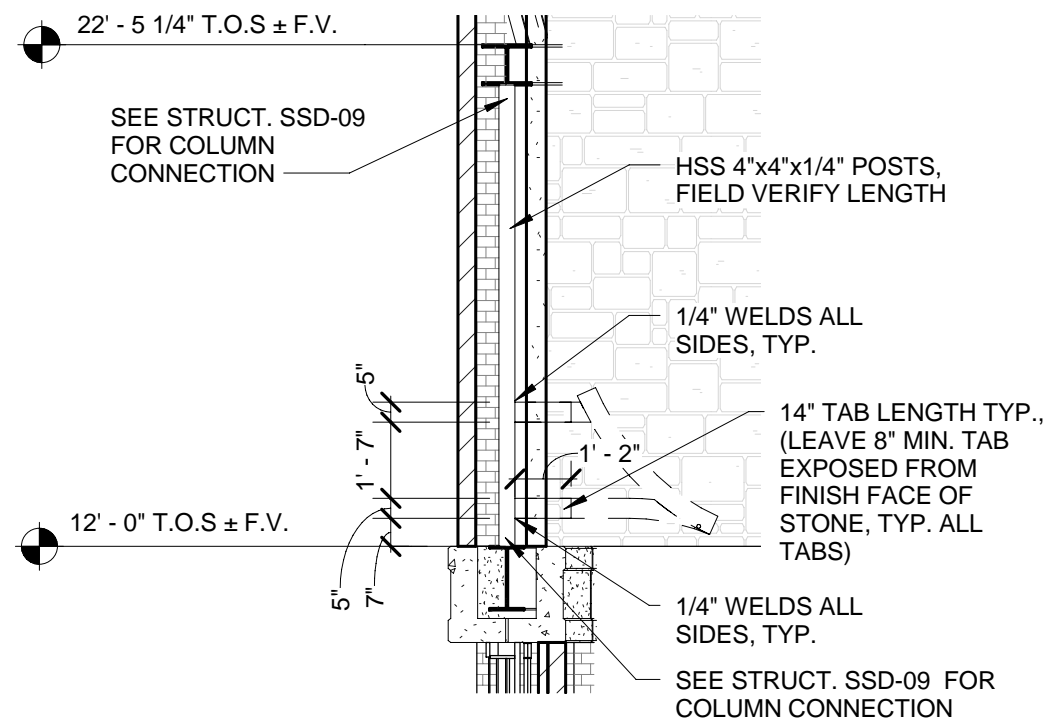

5 Copy of Baptistry Rib - O
1/4" = 1'-0"

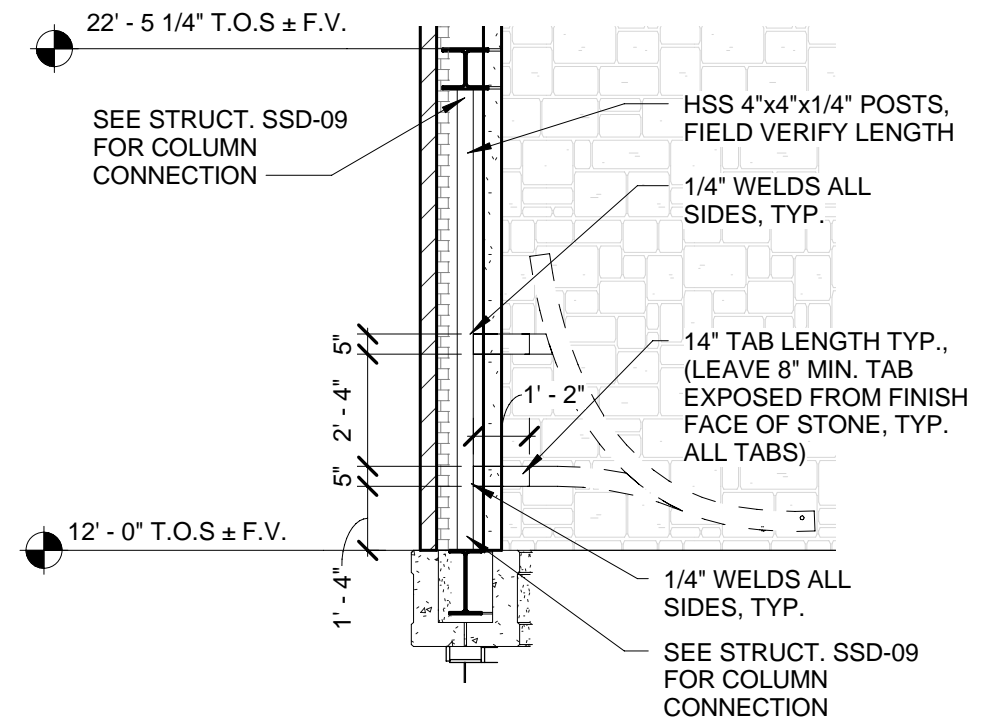

4 Copy of Baptistry Rib - L
1/4" = 1'-0"

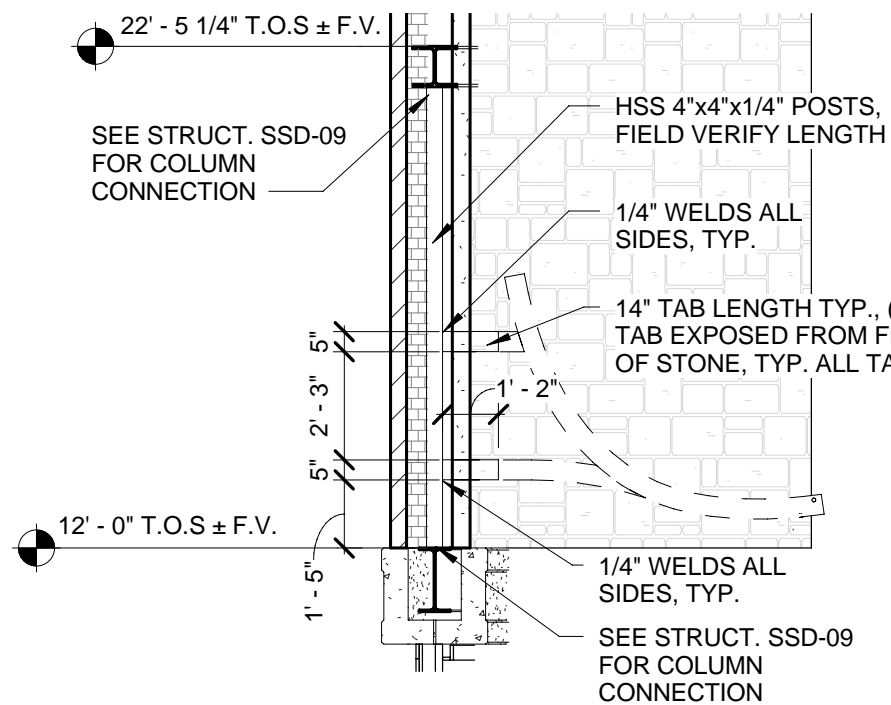

3 Copy of Baptistry Rib - K
1/4" = 1'-0"

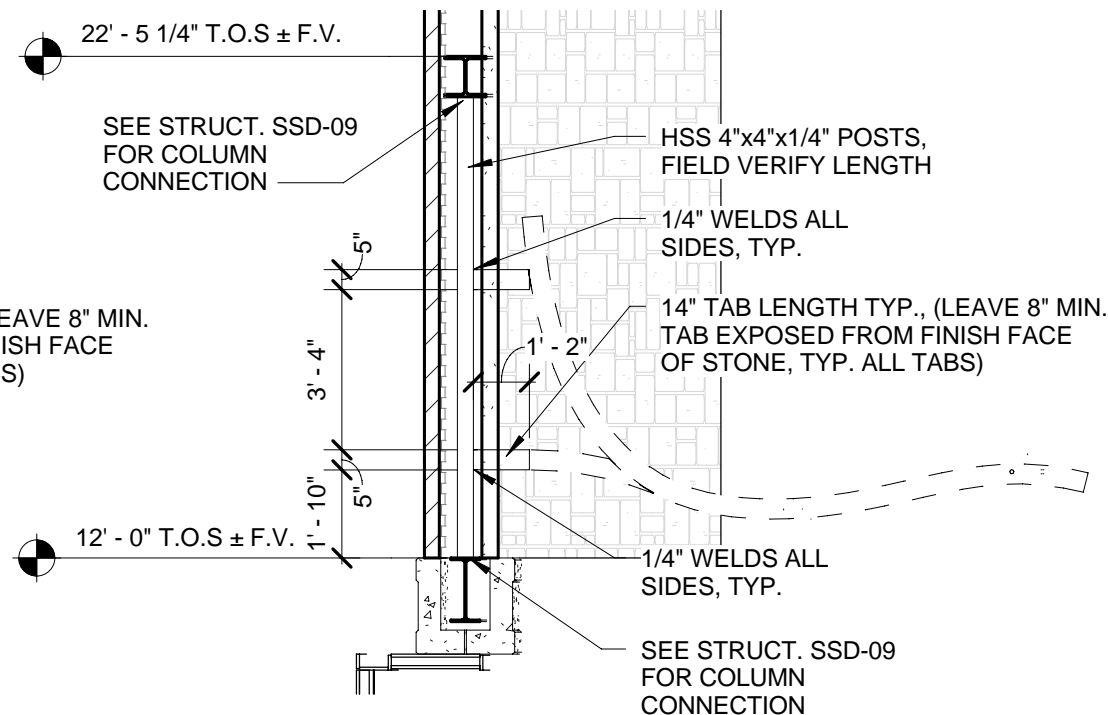

2 Copy of Baptistry Rib - F
1/4" = 1'-0"

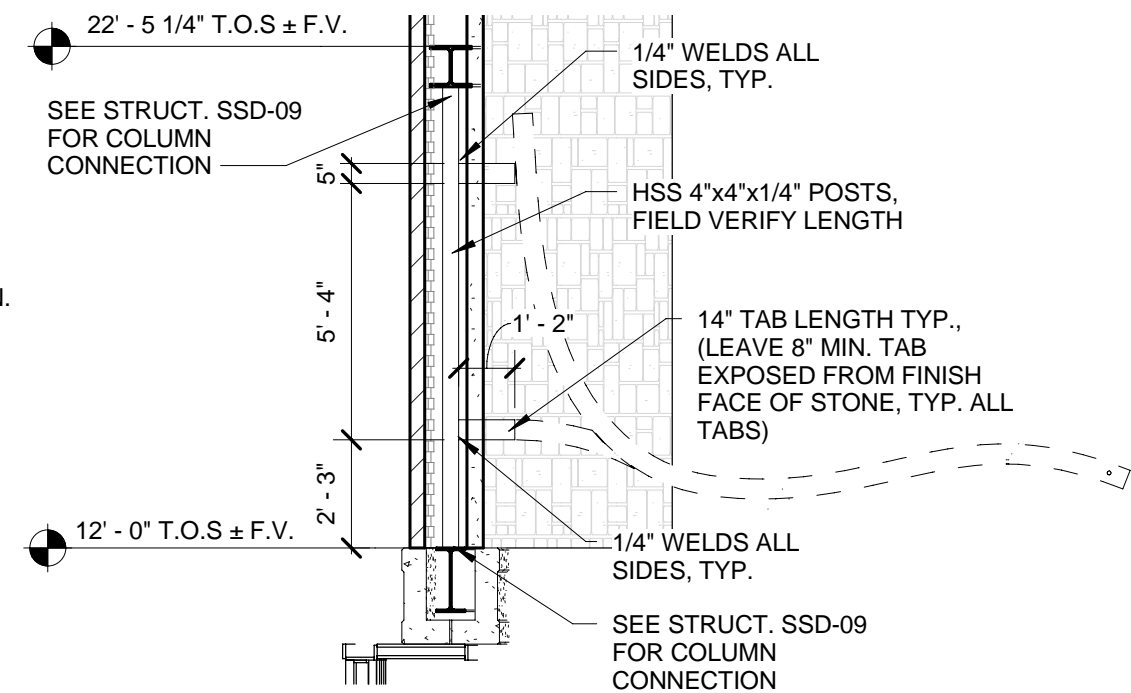

1 Copy of Baptistry Rib - E
1/4" = 1'-0"



BCDM PROJECT NO. 0364-07	SUPPLEMENTAL DRAWING	ATTACHMENT
DATE: 23 APRIL 2010		ASD-20

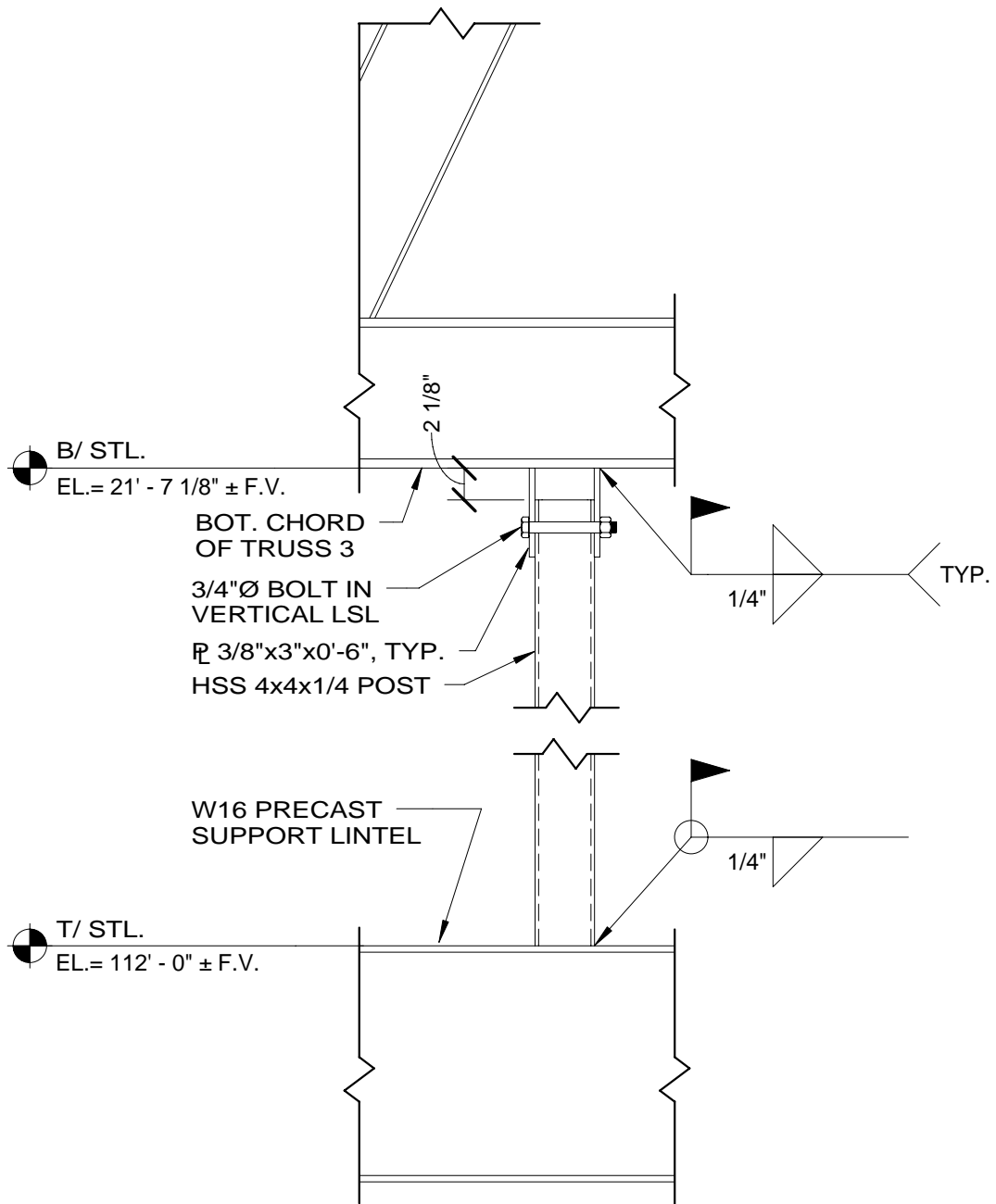

**BAPTISMAL CANOPY POST CONNECTION
DETAIL**

11
1" = 1'-0"



BCDM PROJECT NO. 0364-07	DRAWING REFERENCED:	11/S6-1	ATTACHMENT
DATE: 23 APRIL 2010			SSD-09

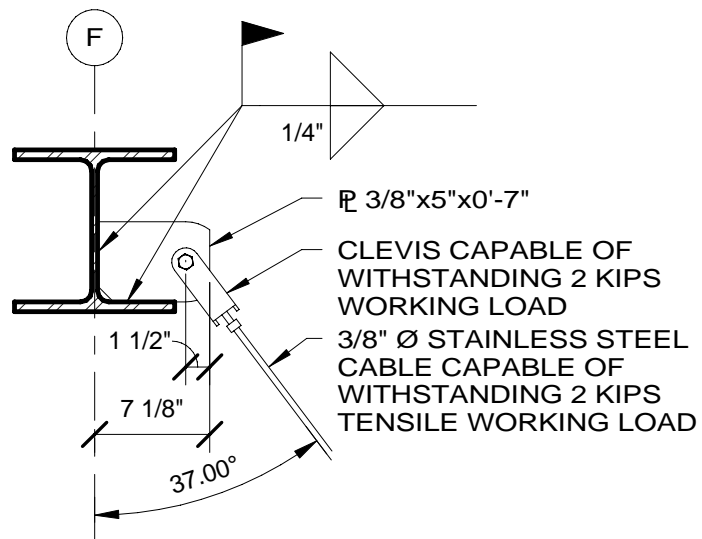

6 CLEVIS PLATE 'C' ELEVATION
1" = 1'-0"

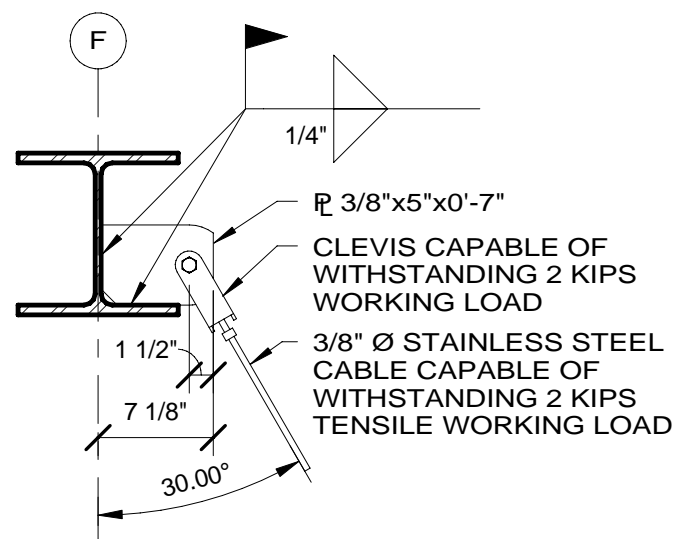

5 CLEVIS PLATE 'B' ELEVATION
1" = 1'-0"

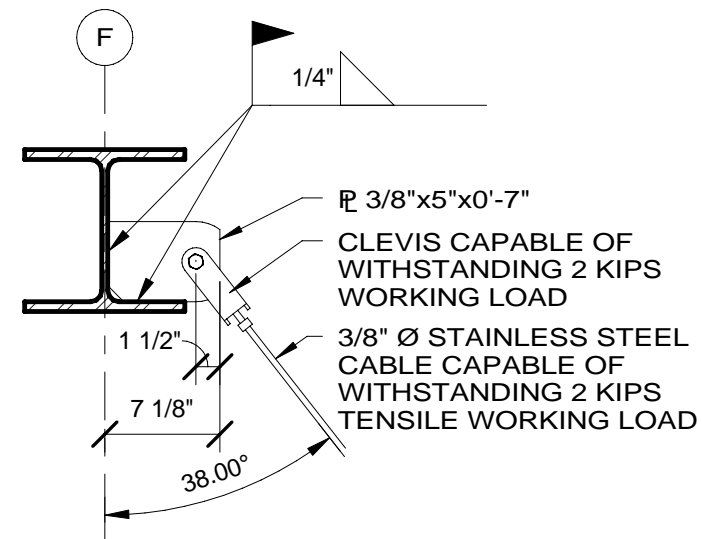

4 CLEVIS PLATE 'A' ELEVATION
1" = 1'-0"

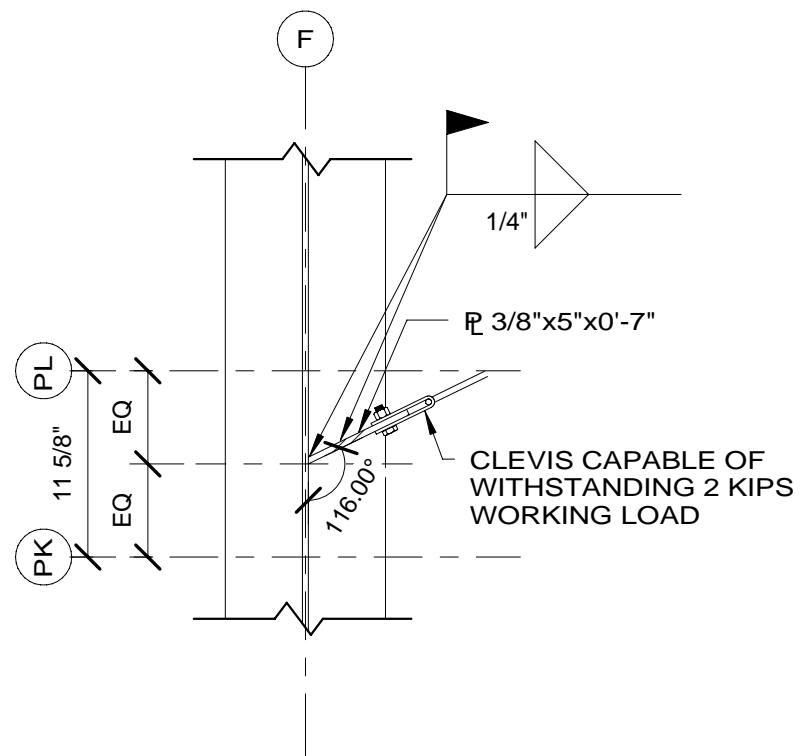

3 CLEVIS PLATE 'C' PLAN DETAIL
1" = 1'-0"

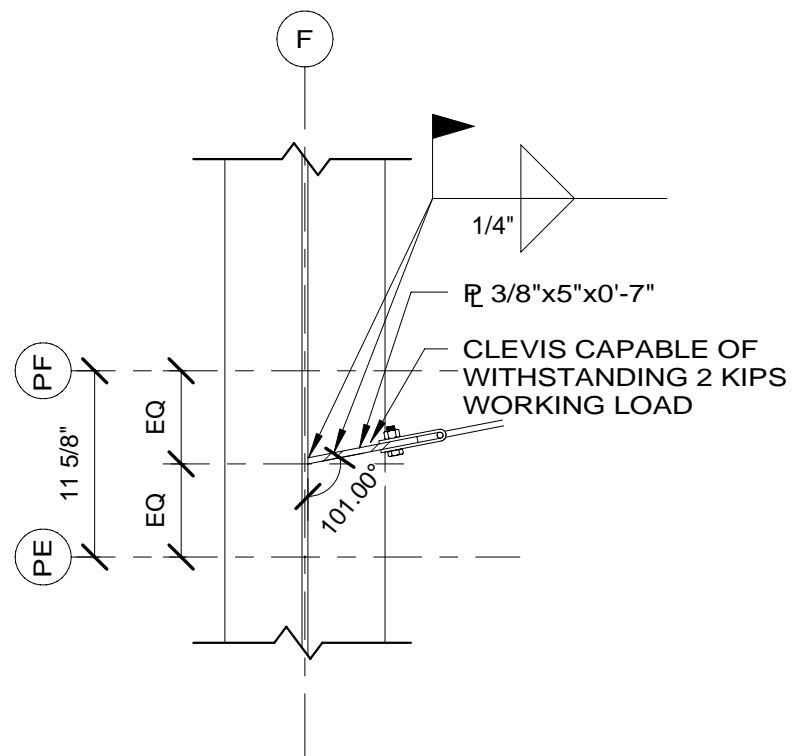

2 CLEVIS PLATE 'B' PLAN DETAIL
1" = 1'-0"

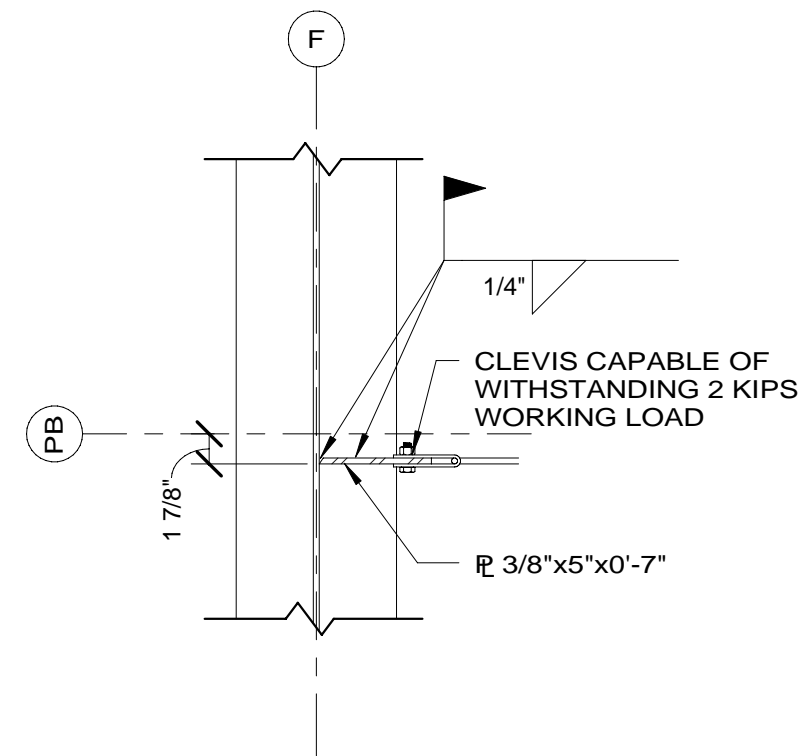

1 CLEVIS PLATE 'A' PLAN DETAIL
1" = 1'-0"



BCDM PROJECT NO. 0364-07	SUPPLEMENTAL DRAWING	ATTACHMENT
DATE: 23 APRIL 2010		SSD-10